

BASICS OF 3D PRINTING

with Josef Prusa

INTRODUCTION

You may have heard about 3D printing on TV, or read about it on the internet. Like all new technologies, 3D printing draws the attention of mainstream media, but the topic is often covered in shallow or sensational ways. There are many myths floating around about 3D printing – including the common misconception that it’s a new technology. In fact, this type of manufacturing method has been known since the 1980’s and it’s now quite commonly used in all sorts of industries, and even by hobbyists at home.

You will find out that 3D printing is not some kind of futuristic, complicated and super-expensive technology available only to a handful of mortals. On the contrary! The principles are pretty straightforward and simple. There are a number of industry-specific words and abbreviations that could, perhaps, frighten you at first – don’t worry about that! Actually, there are not too many of them and you will soon wrap your head around them.

This book will help you understand what kinds of 3D printing technologies are currently available and how they work. We will take you through the whole process of 3D printing, starting with obtaining a printable 3D model, through the pre-printing preparations, to the final post-processing of a printed object. You will learn what an extruder is, as well as slicing, perimeters or infill. We’re going to explain the differences between commonly used materials, and how to utilize 3D printing for practical application.

This book will give you a very good understanding of 3D printing and also provide you with all the basic knowledge required to start. The only thing remaining will be to buy a 3D printer and start printing!

◆ **Josef Průša**

Josef Prusa

Josef Prusa (*23.2.1990) became interested in 3D printing before joining Prague’s University of Economics in 2009. Soon, Josef grew into one of the leading developers of Adrian Bowyer’s international open-source RepRap project. Today, you can see the Prusa design in different variations all around the world. It’s one of the most popular 3D printers and it’s one of the reasons why the knowledge of 3D printing has increased among the public. In 2012, Josef established Prusa Research, which produces the Original Prusa 3D printers and delivers them to customers worldwide.



TABLE OF CONTENTS

What is 3D printing?	4
History of 3D printing	5
Discovery of Stereolithography	5
The RepRap Project	5
The use of 3D printing	6
3D PRINTING TECHNOLOGIES	10
FDM/FFF	11
FFF 3D printers components	13
SLA - stereolithography	16
MSLA printer components	18
SLS / DMLS	20
Choosing a 3D printer	21
3D printing 101	23
Getting a 3D model	25
Online libraries and 3D hubs	25
3D modeling software	26
Tinkercad	26
Autodesk Fusion 360	27
Blender	28
OpenSCAD	29
Things to keep in mind when designing a model	30
3D Scanning and Photogrammetry	34
Choosing the right printing material	35
Slicing	35
PrusaSlicer	36
Simplify3D	37
Cura	37
Slicer - basic settings	38
Preparing the print surface	41
Starting the print	42
Post-processing	42
Gluing and smoothing models using acetone	43
Filaments	44
PLA	46
PETG, ASA and ABS	47
FLEX	48
Composite materials	48
PVA and BVOH for soluble supports	49
Other materials	49
Photopolymers / Resins	50
Multi-color 3D printing	52
Glossary	54
FAQ	58

WHAT IS 3D PRINTING?

3D printing is an automated additive manufacturing process, where a 3D printer creates a physical model based on digital data (a 3D object). There are a number of various 3D printing technologies, but the most commonly used one, called FFF (Fused Filament Fabrication), is simple: an object is created layer by layer by melting a strand of plastic. Imagine that you would take a 3D object and slice it into thin pieces – like a potato into potato chips. Then, you would take a glue gun and "draw" each layer with hot glue. This is generally how objects are printed – it's an additive method, because we're adding material. It's directly opposite to the subtractive method, which consists of machining of existing material.



3D printing is expanding and evolving rapidly. There's a constant and ongoing development of 3D printers and printing materials. 3D printers successfully expanded from the professional sphere into the hobby/maker world.

History of 3D printing

At first, 3D printing was called Rapid Prototyping - and this term is still used today, although rarely. Before affordable 3D printers became commonplace, this technology had been used for prototyping only.

A typical job for rapid prototyping would be the development and production of a TV remote. Preparation works for the manufacturing can cost even tens of thousands USD (manufacturing the molds, the manufacturing process itself, testing...), so the manufacturer needs to be perfectly certain that their TV remote fits well into users' hands and all buttons can be reached comfortably. That's where prototyping comes in. Even though the prices of 3D printers were really high, the cost for manufacturing a single prototype using the old methods was around a thousand dollars, which would still save a lot of money. However, due to the costs of the machines, there was no chance they could get into the hands of ordinary users – fortunately, this situation has changed.

Discovery of Stereolithography

3D printing, as we know it today, was discovered in 1984, when the founder of 3D Systems, Charles W. Hull, applied for a patent for his invention - stereolithography. Hull was the first to print digital 3D data. This technology, commonly abbreviated as SLA, is used to this day. You can learn more about it in the chapter describing various 3D printing methods.



First commercial 3D printer

In 1992, 3D Systems began to produce and sell the first commercially available 3D printer based on the SLA technology.

The RepRap Project

2005 was probably the most important year in the history of modern 3D printing: the RepRap project was created by Dr. Adrian Bowyer at the University of Bath. The idea was to develop a 3D printer that is capable of printing as many of its own parts as possible. The project was conceived as open-source from the very beginning, which means that all source codes are available publicly for free and they are open

WHAT IS 3D PRINTING?

to further modifications and improvements. This was an important decision that allowed enthusiasts from the whole world to take part in the project. And it's the main reason why the RepRap machines are currently the most widespread 3D printers in the world. Thanks to RepRap, we can now buy 3D printers for the DIY/maker and semi-professional markets - these are usually machines under 4,000 USD.

The community around RepRap printers is huge. If you want to understand how 3D printers work (or you want to try various upgrades, mods and experiments), RepRap is the perfect solution for you. These 3D printers can be purchased either as calibrated and fully assembled machines, or as DIY assembly kits, which are pretty fun to build - and actually less complicated than you might think.



Adrian Bowyer (left) with his RepRap 3D printer

The use of 3D printing

3D printing was, at first, used as a means for creating cheap and quick prototypes. As technologies became less expensive, 3D printers found their uses in other industries.

One such example is small-series productions. There are companies manufacturing low volumes of their products and the high costs related to high-volume production would not be justified in such cases. Therefore, 3D printing comes in as a more suitable solution. Another useful aspect is the fact that when you come up with an improved design, you can start producing it immediately, which means you can introduce new and improved products at a much faster rate than usual.

We have embraced this approach with the production of our Original Prusa i3 3D printers. Our in-house 3D printing farm has now over 500 printers. When there's a redesigned or improved part, all we need to do is to test it and then upload it to the printing farm system - the production can start pretty much immediately. Plus, we can also send the data to our customers, so they can print the parts themselves right away. The possibility of quick iterations is one of the biggest strengths of 3D printing.



Prusa Research print farm

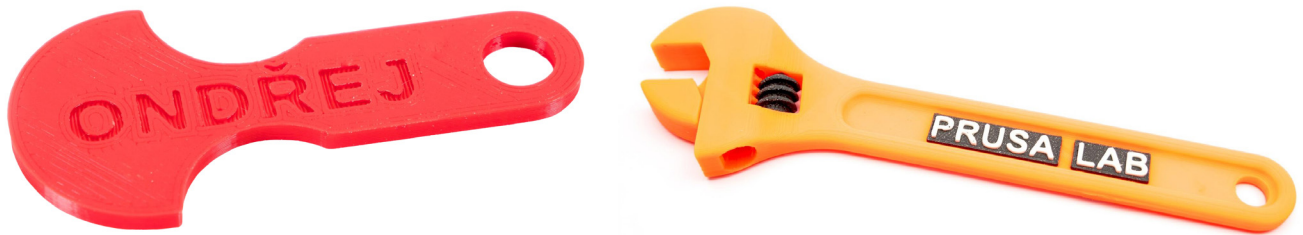

Personalized production enables manufacturers to produce customized items based on customers' requests. This can be, for example, a smartphone case with an individual motif, a customizable keychain or various marketing items modified to suit the customer's needs.



A 3D printer is also great for producing **toys and figures**. You can find thousands of free or paid models on the internet, ranging from simple toys to meticulously crafted tabletop games.



Cosplay* fans will find 3D printers especially useful, because they can be used to produce masks, equipment, accessories and other items that can be easily post-processed (sanded and painted) to give them an authentic look.

* Cosplay - portmanteau of the words 'costume play'. It's a performance art in which the participants (cosplayers) wear costumes to represent a specific character from books, films or video games

WHAT IS 3D PRINTING?



www.thingiverse.com

Another area where 3D printers really shine is the production of spare parts that are no longer available through official channels. It's quite common that when it comes to restoration and repairs of antiquities or oldtimer/youngtimer cars, certain parts are no longer available – and you often need just that one thing. The same applies to repairs of home appliances, or manufacturing of various covers, boxes or holders. Guaranteed, if you buy a 3D printer, you will soon see its effect everywhere in your house!



www.archprint.cz

3D printers are a huge thing in architecture and construction spheres. One of the most important parts of architectural projects are 3D visualizations. These are still often showcased as 2D images on a computer screen, which may not be ideal. Many architects have decided to switch to 3D visualization. Thanks to the increased popularity (and usability) of virtual reality, it is now possible to take a tour through a digital building. However, another great option is to actually print a small-scale replica of the planned project to have something more physical than just a digital rendering.



3D printing enables architects to create models faster and in a more efficient manner. The goal is to bridge the communication gap between the architect and the customer using a physical print instead of computer data.

This is not everything, of course. 3D printing is used in many different industries, including car and aviation industries, healthcare, RC models, jewelry and many others. New uses for 3D printing are discovered almost every day.

So regardless of whether you need a new frame for your drone, a cable holder or anything between that, you can make it with a 3D printer. It makes life so much easier!

3D PRINTING TECHNOLOGIES

All types of 3D printing are based on the same principle: creating objects by adding layers on top of existing layers. As of this moment, there is no 3D printing technology that would be completely universal and suitable for every purpose. This is why it's important to decide how and for what purpose you are going to use the printer. To make things easier, let's divide 3D printer types into three main categories:

1. A strand of plastic melted by a heating element and extruded by a printing head (extruder) through a nozzle. This is a typical description of the FFF (Fused Filament Fabrication) / FDM (Fused Deposition Modelling) technologies. These terms can be considered to be synonyms. FDM is a trademark of Stratasys.
2. Liquid material solidified into layers in pre-defined areas. This is what we usually call SLA - Stereolithography Apparatus. The liquid material (resin) is cured by a ray of light (UV laser or LED panel, DLP projector).
3. Fine powder sintered (compacted and formed, not melted) by a laser. The technology is called SLS (Selective Laser Sintering) and compared to the previous two, it's much more expensive.

FDM/FFF

The most widespread and most affordable 3D printing technology, suitable for printing functional / mechanical parts and prototypes. The printer uses strands of plastics as the main resource. The spool of plastic is called filament and it is usually available with a diameter of 1.75 mm. There are still some 3mm filaments on the market, however, their printing accuracy is quite low, and using them is not recommended. Compared to liquid resins or powdered materials, filaments are safe and easy to work with. The downside is that the layers on the printed objects are visible to the naked eye. The usual layer height (when using a 0.4mm nozzle) is between 0.05 to 0.3 mm.



The price range of FFF printers starts at around 150 USD for cheap 3D printers from China and can go way beyond 100.000 USD for professional machines. Original Prusa i3 MK3S 3D printer starts at 749 USD / 769 EUR and it represents an ideal compromise between price and quality.

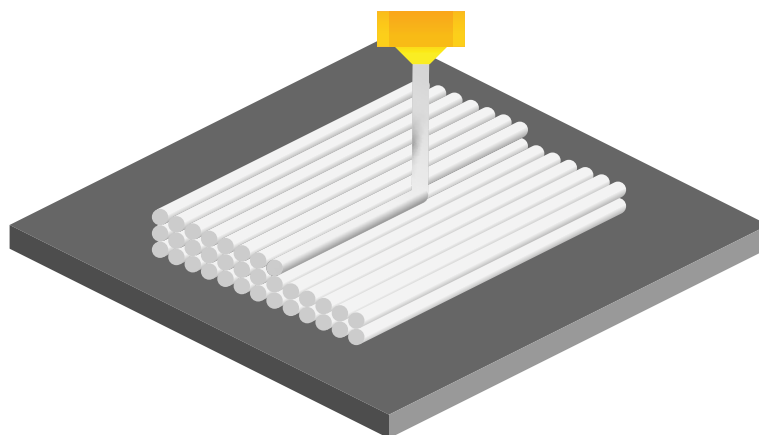

We can divide FDM / FFF 3D printers into sub-categories based on the movement of their axes in three-dimensional space.

1. **Cartesian** 3D printer is named after the XYZ dimensional coordinate system. The extruder moves in two directions (X and Z), while the print bed moves along the Y-axis. It also means that the print bed is usually square- or rectangle-shaped. Original Prusa i3 MK3S is a cartesian printer.

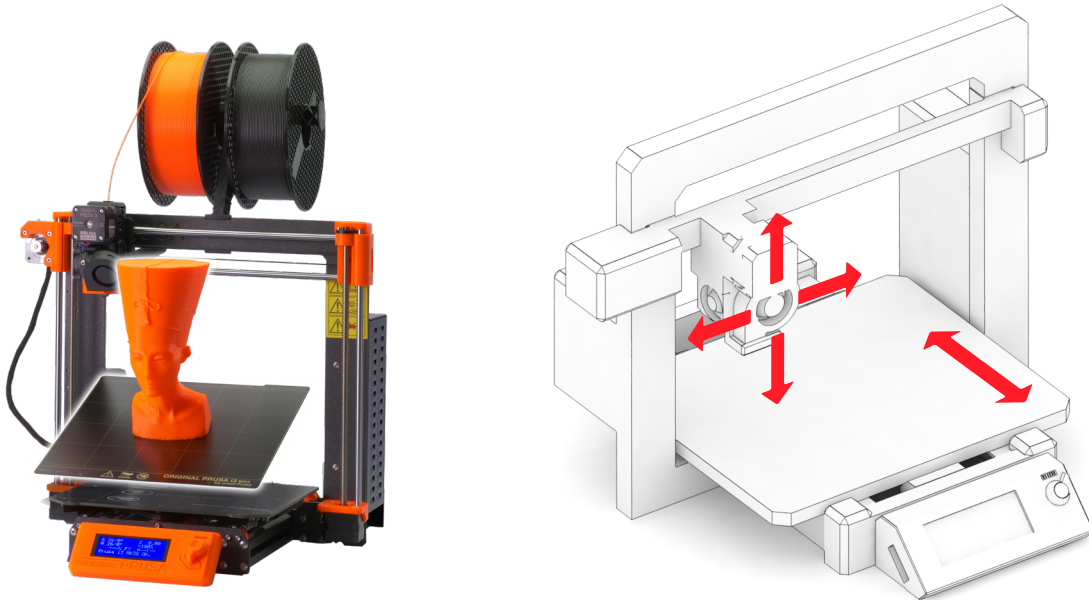

2. **Delta** 3D printers have their extruder movements controlled by three moving arms, which meet in the extruder. Two of the biggest advantages are the speed of printing and large printing volumes. However, the printer requires extremely precise assembly and calibration. The printer's geometry requires complex calculations for movements of stepper motors in each of the arms.

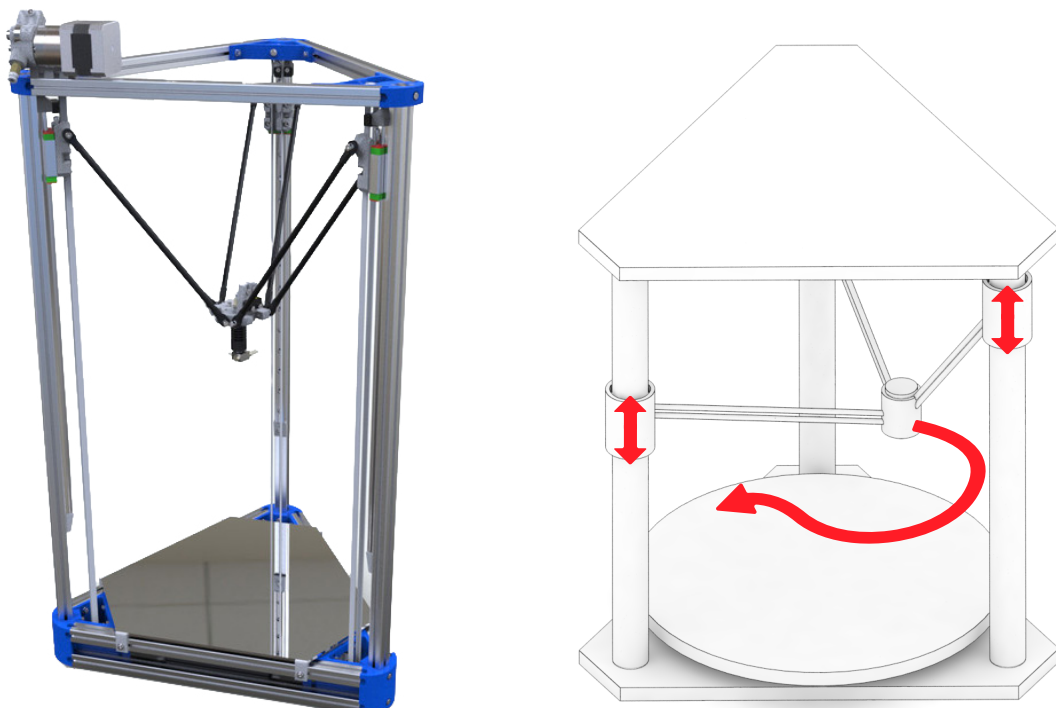

- 3. Polar** 3D printers are relatively uncommon. They are based on a polar coordinate system. The extruder moves in two axes and the print bed rotates. This system is pretty simple construction-wise, however, the preparation of the model is rather complicated.



FFF 3D printers components

All FFF 3D printers are quite similar construction-wise. They usually consist of the following parts:

Extruder

Extruder, or a print head, is designed to lay down printed layers by extruding melted plastic.

First, the filament strand enters the extruder through a PTFE tube. At this point, the filament is a solid plastic strand and is at the room temperature. It goes through a heat sink, which is a part designed to dissipate heat coming from the heat break and minimize the transition area between solid and melted filament. The heat sink usually has a fan mounted on the side to increase the cooling efficiency. The heat break is essentially a piece of tube with an outer thread, which is narrower on one end to minimize the diameter as much as possible, so there's less heat rising up towards the area, where the filament should remain solid.

The heater block is made of heat conducting materials, usually aluminum, and contains a small electrical heating element along with a thermistor for measuring the temperature. The material is melted in the heater block and it is pushed further and out through the nozzle. The nozzle can have different diameters and many printers allow the users to change the nozzle to a new one with a different diameter. You can read more about nozzles with various diameters and their benefits in an article at blog.prusaprinters.org/nozzles.

Extruder

- 1 PTFE tube
- 2 Heatsink
- 3 Print fan
- 4 Heat break
- 5 Heater Block
- 6 Nozzle

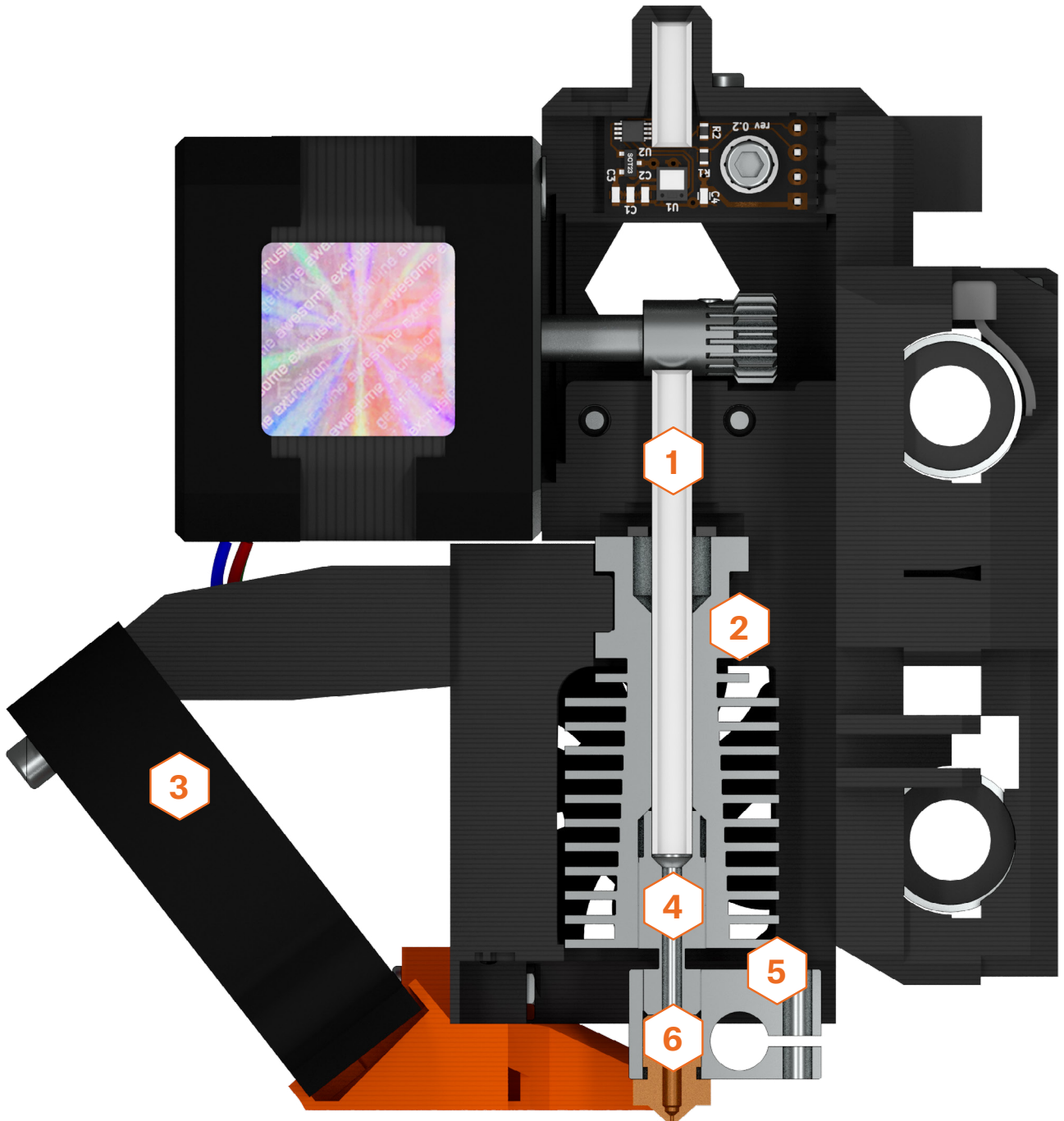

Heated bed

Heated bed or Heatbed is an important part of every modern 3D printer that should be compatible with as many materials as possible. The heated bed stops printed objects from bending, warping or detaching from the surface.

Frame

The frame is the supporting structure of the printer. Rigid and precisely manufactured frames have a positive impact on the printing quality. A robust and firm frame minimizes vibrations and allows for a faster print without noticeable quality issues on produced prints.

Stepper motors

Stepper motors take care of movements in all axes – this includes the extruder and the heated bed, while another motor controls the movement of the filament string. The advantage of stepper motors is the fact that the steps can be precisely controlled.

Mainboard

The mainboard is an electronic component with integrated circuits that controls the whole printer. Its primary function consists of reading instruction files (G-Codes) and controlling the motors, heated bed and heater based on the instructions found within the G-Code.



Heated bed



Frame

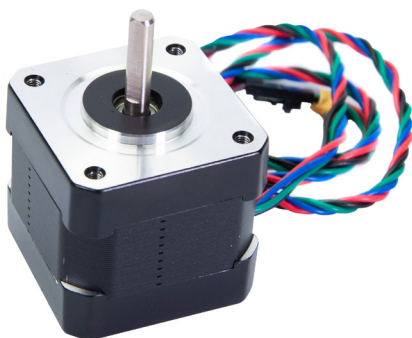

Stepper motors

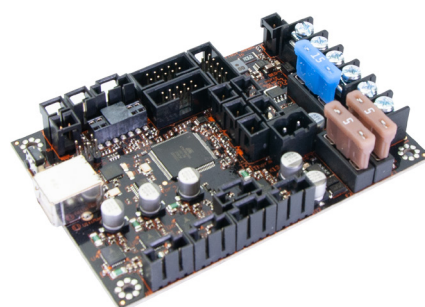

Mainboard

SLA (Stereolithography)

The SLA technology is based around photosensitive liquid resins that can be cured (solidified) by UV light. SLA 3D printers have a platform that moves once a layer is solidified to create space for a new layer that adheres to the previous one. Compared to FFF printers, the objects are noticeably more detailed, however printing usually takes longer and the print volume is smaller. These printers are especially suitable for industries as jewelry or medicine. Printed objects are almost perfectly smooth, incredibly detailed and layers are nearly invisible to the human eye – especially compared to FFF printers. The biggest disadvantage of this technology can be a smaller print surface area and also the toxicity of liquid resins. You should try to prevent resins from touching your skin and avoid inhaling resin vapors.

- 1 Printing platform
- 2 Trapezoid rod
- 3 Z-Axis
- 4 Resin tank
- 5 Photopolymer (liquid resin)
- 6 Stepper motor
- 7 Printed object

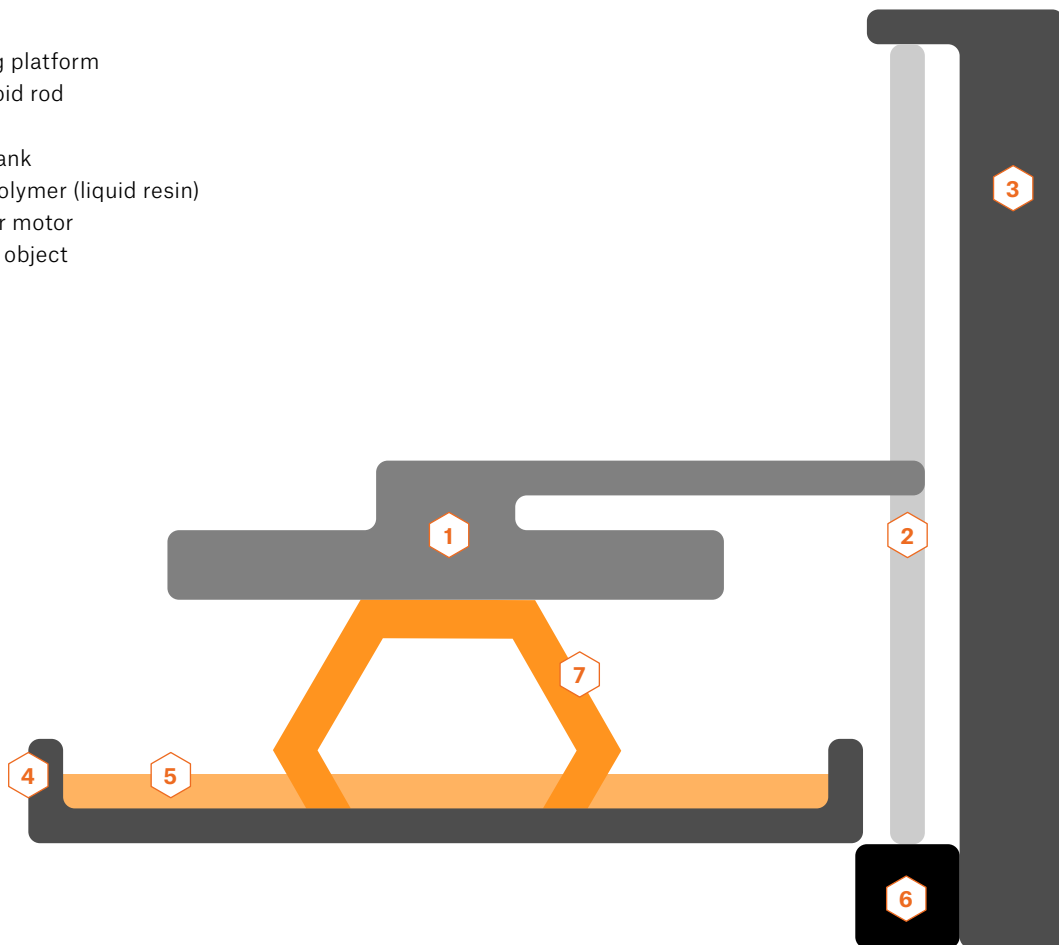

However, with SLA machines, things usually don't stop at the end of the print. Printed objects are not fit for immediate use after the print job finishes, since they tend to be a bit soft and sticky - which is caused by the leftover unsolidified resin on the surface of the object. It is recommended to wash the object in isopropyl alcohol and to cure it further using UV light. All this should be done very carefully while wearing protective gloves. Fortunately, there are machines that can take care of both things automatically. The Curing and Washing Machine (CW1) is an optional accessory for our Original Prusa SL1, which can do all of this quickly and easily.

There are three main types of SLA printers. They differ based on the exposure methods. Even though they may seem similar, the printing quality can differ greatly.

- 1. SLA - Laser** – exposure is performed with a ray of UV laser. The ray is controlled by two mirrors and it “draws” each layer gradually. The time required to solidify a single layer depends on the size of the area which needs to be solidified. Simply put: the more objects there are on the print platform, the longer the print takes.

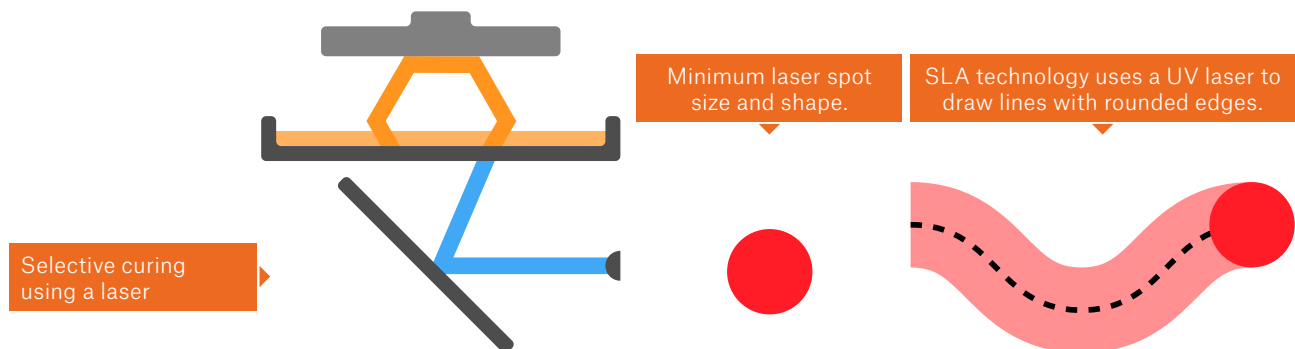

- 2. DLP (Digital Light Processing) - SLA** – the whole layer is solidified at once thanks to a digital projector. The areas that receive the exposure from the projector are solidified. The advantage of this method is obvious - each layer is solidified in the same amount of time, no matter how many objects there are on the print platform.

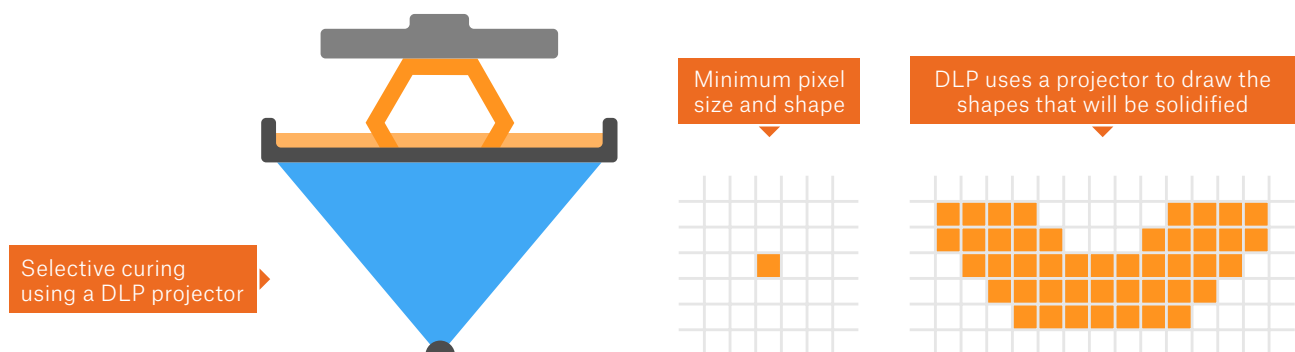

- 3. MSLA (Masked Stereolithography)** – exposure is performed using a high-performance UV LED, while the layer's shape is displayed as a semi-transparent mask on an LCD screen. UV light can pass only through white pixels on the display. Since LCD displays have a fixed resolution, it also means that printed objects have fixed XY resolution. This method also cures a whole layer at a time, meaning it doesn't matter how many objects there are on the printing platform. The Original Prusa SL1 3D printer uses this method.

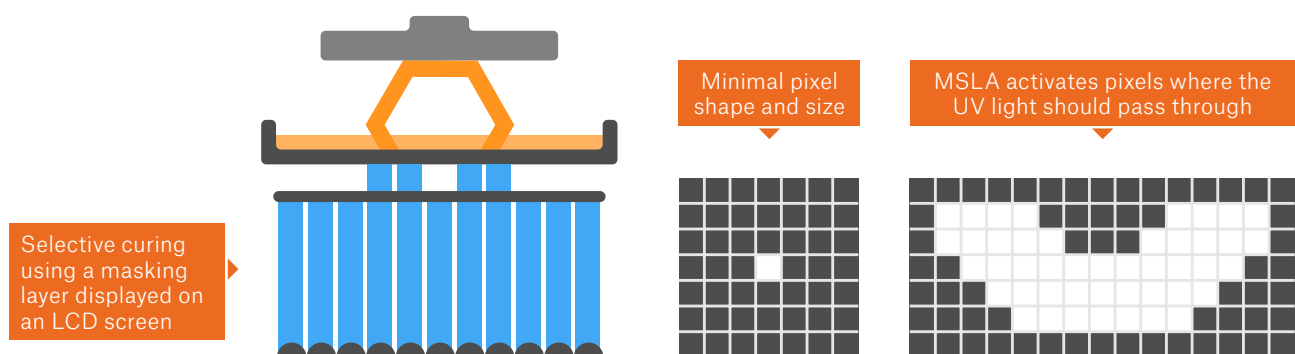

Pictures above are simplified representation of each of the technologies. The depictions of DLP and MSLA technologies are not taking into account such features as anti-aliasing. Without AA, the edges of the mask would be noticeably pixelated. In layman's terms, anti-aliasing can smooth out the sharp edges by averaging colour from nearby pixels. So in our case, there's in fact not just a black and white edge, but the anti-aliasing method actually creates a gradient transition, resulting in smoother lines.

MSLA printer components

The situation with SLA 3D printers is similar to FFF/FDM models - there are different designs, different configurations, depending on how the SLA 3D printer solidifies resins. We would like to focus on MSLA machines, since our own Original Prusa SL1 uses masked stereolithography.

UV LED panel

The high-performance UV LED panel is used to solidify liquid resin in the resin tank. Since we're using a panel and not a single LED, the distribution of UV light is more even, and we can also reach lower (faster) exposure times.

LCD screen

The LCD screen is used for a technique called 'masking'. What does it mean? The UV LED panel shines light into the whole printing area, so without a mask, the only shape it could print, would be a solid block. The LCD screen displays a mask, a black-and-white picture in the shape of a single layer. White pixels allow the UV light to pass through, while the black pixels block it.

Touch screen

This is the printer's second LCD screen, however, this one is not used for the printing itself. Instead, the user can easily configure and control the printer using an easy-to-use interface.

Tank (Vat)

The tank, sometimes called a vat, is the container for liquid resin. It has a transparent bottom, which allows UV light to pass through. The Original Prusa SL1 3D printer even has a special tank tilting mechanism. What is it good for? After each layer is cured, the printed object has a tendency to adhere to the bottom of the tank. Some printers just move the printing platform up - vertically. This creates a lot of surface tension, which could result in damage to the layer. The printed object could even detach from the platform. However, thanks to the tilting mechanism, the layer is separated from the bottom gradually - less force is required, and reliability is increased.

Z-axis tower

The only mechanical movement of the printing platform is in the Z-axis (up and down). Thanks to the masking LCD screen with fixed X-Y resolution, no other movements are necessary.

Acrylic lid

The SL1 features a semi-transparent orange-tinted acrylic lid. It blocks a large portion of UV light coming from the outside (e.g. sunlight), which would otherwise cure the resin in the tank. It also blocks the UV light emitted by the UV LED from leaking out of the printer. Last, but not least, it also partially contains resin fumes inside the printer.

Air filtration

Most of commercially available resins produce prominent odors. This is why the SL1 has a built-in filter.

Solid aluminum frame

The frame ensures that the machine is solid and stable. Softer frames are prone to warping or oscillation, which results in poor print quality.



UV LED panel



LCD screen

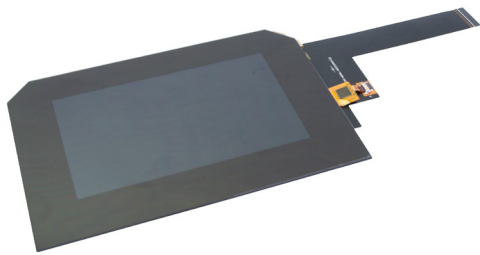

Touch screen



Tank (Vat)

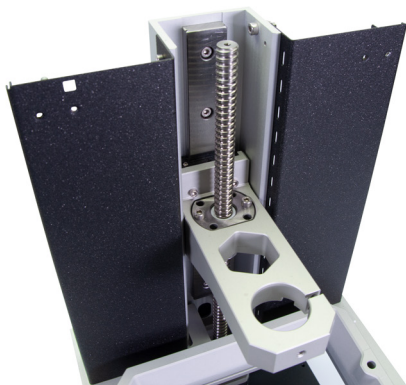

Z-axis tower

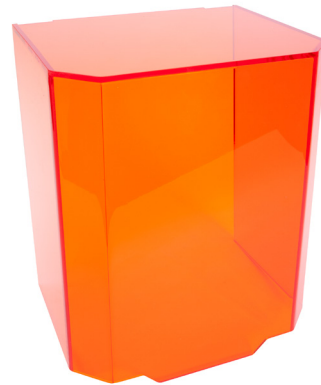

Acrylic lid



Air filtration



Solid aluminum frame

SLA printers are, generally, more expensive than FFF machines - they usually start at around double the price. The cheapest SLA 3D printers are around 450 USD, professional machines are well over a hundred thousand dollars. Our Original Prusa SL1 3D printer starts at 1399 EUR/USD.

SLS / DMLS

Another types of 3D printing technologies are SLS and DMLS, which use a process called sintering. Essentially, every time a new layer is printed, a cylinder spreads a thin layer of fine powder across the platform, which is then sintered with a laser into the required shape. When the print finishes, the whole object is covered with the printing powder. Due to how this method works, the printed objects must have holes, through which the excessive powder is poured out. Unsintered material can be reused for next prints, which means that very little material is wasted. Another advantage is the fact that the layers are nearly invisible.

These printers are not massively widespread among the common public. Due to their main use in various industries, the prices are noticeably higher - the cheapest machines start at around 6000 USD.

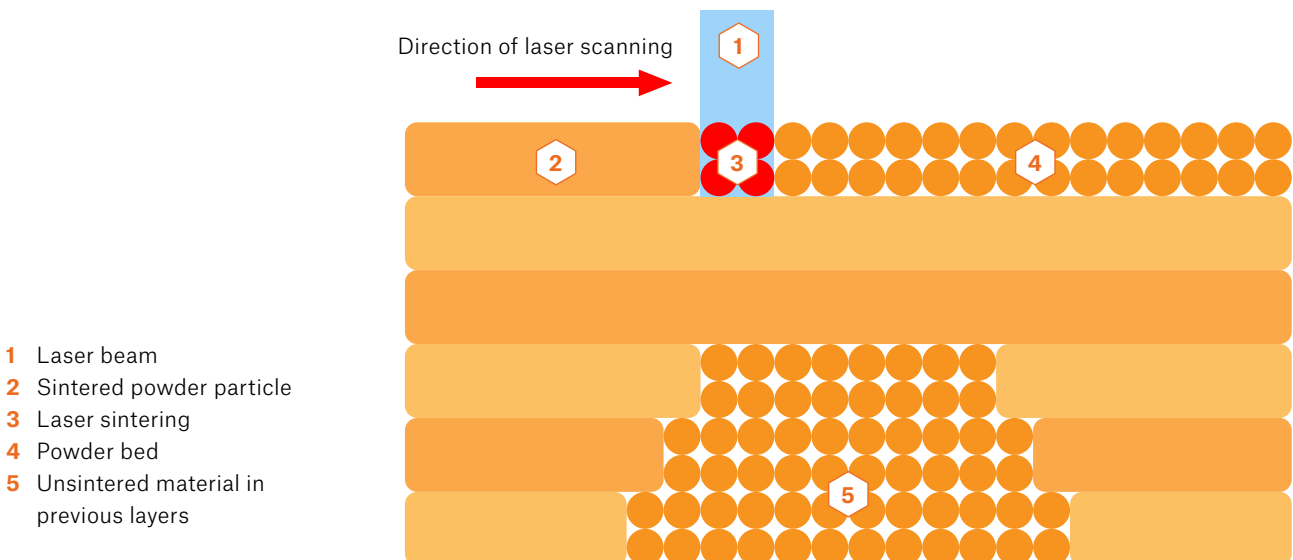
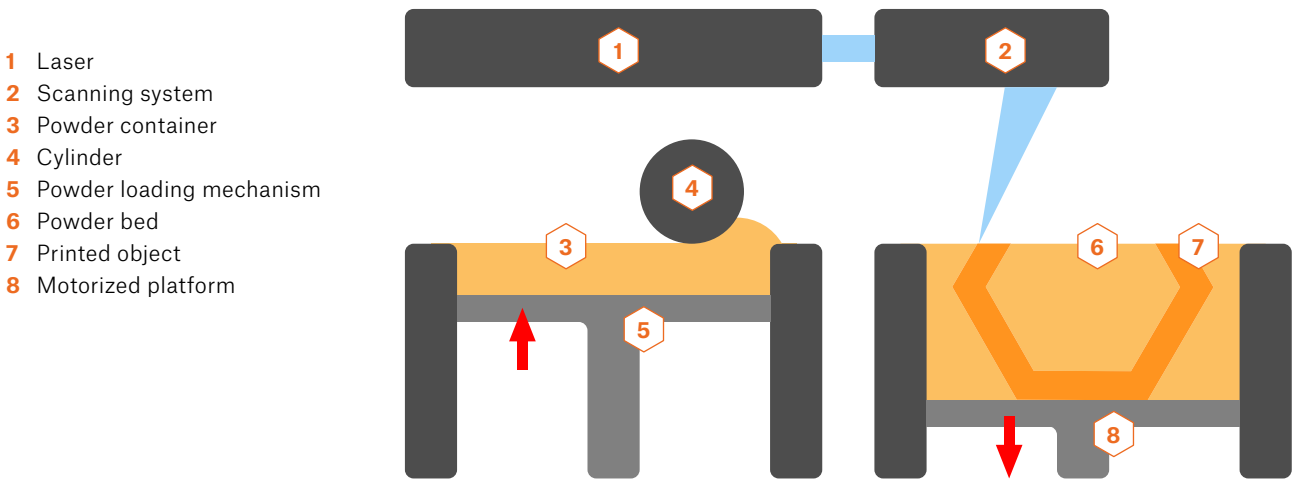

CHOOSING A 3D PRINTER

Once you start choosing a 3D printer, it's always important to decide how and for what purpose it is going to be used. Maybe you were expecting a long list of printers sorted from the best to the worst - but that's pretty much impossible to do without oversimplifying things to extremes. Instead, we would like to present you with a set of questions you should ask yourself before buying a 3D printer. Answering these will help you select the right machine for your purposes.

What price range are you aiming for? Expensive professional printers or cheap Chinese products?

The price reflects the quality of the build and the lifespan of the printer along with other "nice-to-have" features.

What is the customer support for the printer? Is there an active community, which could potentially help me in case I run into trouble? Is the printer open-source? What about spare parts and upgrades?

This is probably the most important question. Communities are becoming one of the most important factors when buying (not only) a 3D printer. The situation is similar with e.g. smartphones - manufacturers supports their models with new updates only for a limited time, however, if there's an active community, the members can work on their own updates and extend the lifespan of the device. The same applies to 3D printers - open-source-based projects are ideal for active communities.

What are the running costs?

Certain manufacturers only allow use of their own branded materials and spare parts. This increases the running costs and also limits the range of supported materials.

How large printing surface do you really need?

It may look like it's better to have a huge printing surface, however, in most cases it's just a huge money waster. Objects made from PLA can't be usually larger than 20 cm in one axis, due to thermal expansion, which causes larger objects to warp and detach from the print surface. Don't forget that you can always cut the model into multiple pieces and glue them together.

How detailed prints do you need?

The quality and the level of detail of objects printed on an FFF printer can be affected by using a nozzle with a different diameter and by selecting the right materials, speed and temperatures. Although, it's true that the level of detail on FFF printers is lower than on SLA printers.

Is a single-material printer good enough, or do you need a multi-material (or even a full-colored) 3D printer?

You will find out more about multi-colour printing in the next chapter.

You should decide for yourself, what are the best options for you, personally. Many of them are direct opposites, which means some compromises will be needed. In layman's terms: if you are ok with a smaller printing area and you need high-quality prints, SLA is the way to go. However, most users will be perfectly happy with an FFF 3D printer.

3D PRINTING 101

The 3D printing process consists of three main steps. First, you need to obtain a printable 3D model. Then, you should prepare it for printing, and the last step is the printing job itself. Let's take a look at everything from a general perspective. Then, we'll go more into detail.

The first step is to obtain a 3D object, which is typically an STL file. However, this format is not recognized by 3D printers and it is not directly printable. To process an STL file, you need to use a specialized tool, commonly known as 'slicer'. There are different slicers on the market, some are free (PrusaSlicer), others are paid (Simplify3D) and they are usually compatible with a limited range of printers, so you need to choose the right one for your machine. You can import an STL file into the slicer of your choice, configure printing parameters and then export the final result as a 'G-code', which is basically the original 3D object sliced into thin layers and converted into a set of movement commands recognized by 3D printers. Furthermore, slicers insert additional information into G-codes, such as temperature information, cooling settings and others. The resulting G-code is printer-specific, so that's why 3D objects are usually shared as STL files - users can then slice them for their printer / filament individually.

The diagram below depicts the individual steps leading towards a successful 3D print.

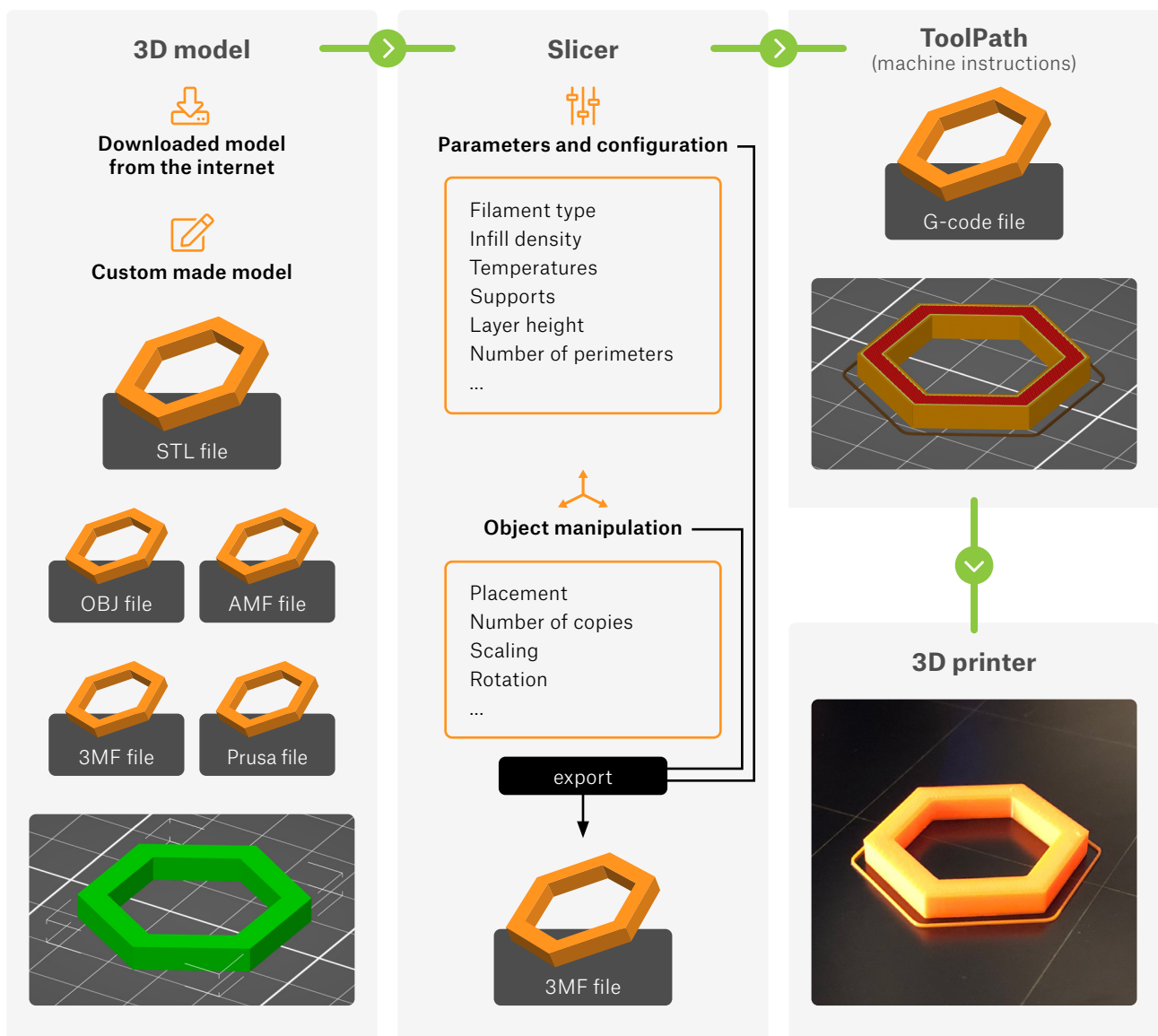

Getting a 3D model

Generally speaking, a 3D model can be obtained through one of the following ways:

1. **Downloading a 3D model from the internet**
2. **Creating your own models**
3. **3D scanning a real-world object**

Online libraries and 3D hubs

The easiest way how to get started with 3D printing is to find 3D objects available on the internet for free. They usually come in .stl or .obj file formats. There's a number of websites that offer a wide range of downloadable models - the best ones are listed below.:

PrusaPrinters

Free models

www.prusaprinters.org

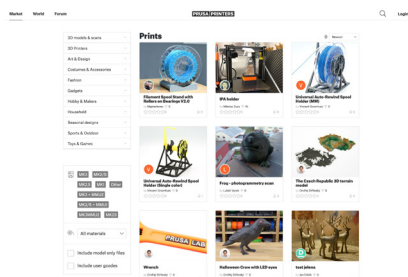

Community hub for all Prusa printer owners, and the only online library offering pre-sliced and print-ready G-codes! But it's much more than just a library of STL or 3MF files! Join now and engage with the community in a variety of ways!

Thingiverse

Free models

www.thingiverse.com

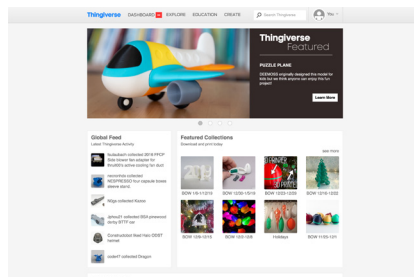

Thingiverse is the richest 3D archive on the internet. Currently, it offers more than 1.2 million models for free download - and the number keeps growing every day. It became a popular place for downloading, sharing and showcasing all sorts of 3D models.

YouImagine

Free models

www.youmagine.com

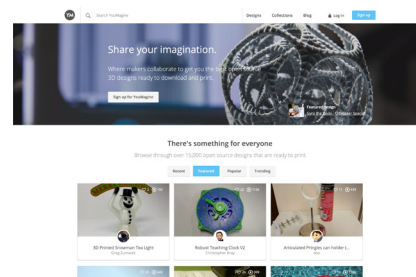

YouImagine is a community website backed by Ultimaker. Models are divided into popular categories or collections curated by the site's users. As of right now, the portal offers over 15,000 models for download.

Pinshape

Free and paid models

www.pinshape.com

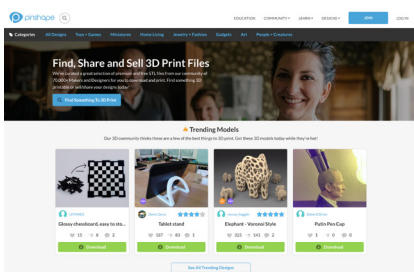

According to the creators, Pinshape is a shop with high-quality 3D models. However, the website also offers many models for free. Designers can use this web to sell their own creations.

MyMiniFactory

Free and paid models

www.myminifactory.com

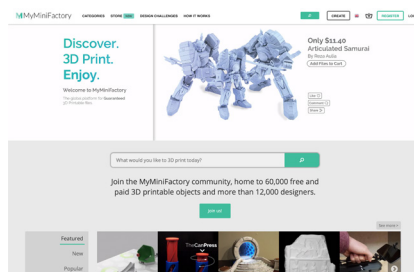

A popular repository with around 50,000 models by professional designers. All models are tested before publishing, so you can be sure you're getting great quality STLs. The price of paid models is usually between 4 to 40 USD.

Cults

Free and paid models

www.cults3d.com

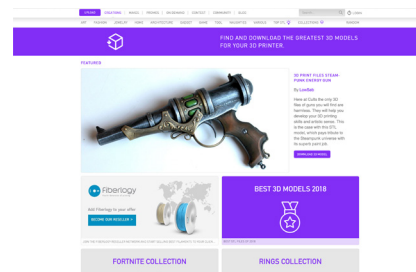

A repository with more than 25,000 free 3D models and several thousands of paid models. An interesting difference between this site and the rest are various collections based around popular brands, such as Lego, IKEA or GoPro.

3D modeling software

Nowadays, you can pick from a wide range of various 3D modeling applications. There are simple and easy-to-learn (and often web-based) applications such as TinkerCad. You can try parametric modeling with OpenSCAD, or use a fully professional tool such as the popular Autodesk Fusion 360. All these applications enable you to create a model and export it as an STL file.

Tinkercad

Tinkercad is a great and intuitive tool for beginners. It's free, although a registration is required. You can find plenty of tutorials, guides and tips online. TinkerCad is built around the idea of a basic library with various shapes, which can be dragged into the main window and further modified. The application lacks advanced functions, however, it can import and edit an existing STL file. Tinkercad is available at www.tinkercad.com.

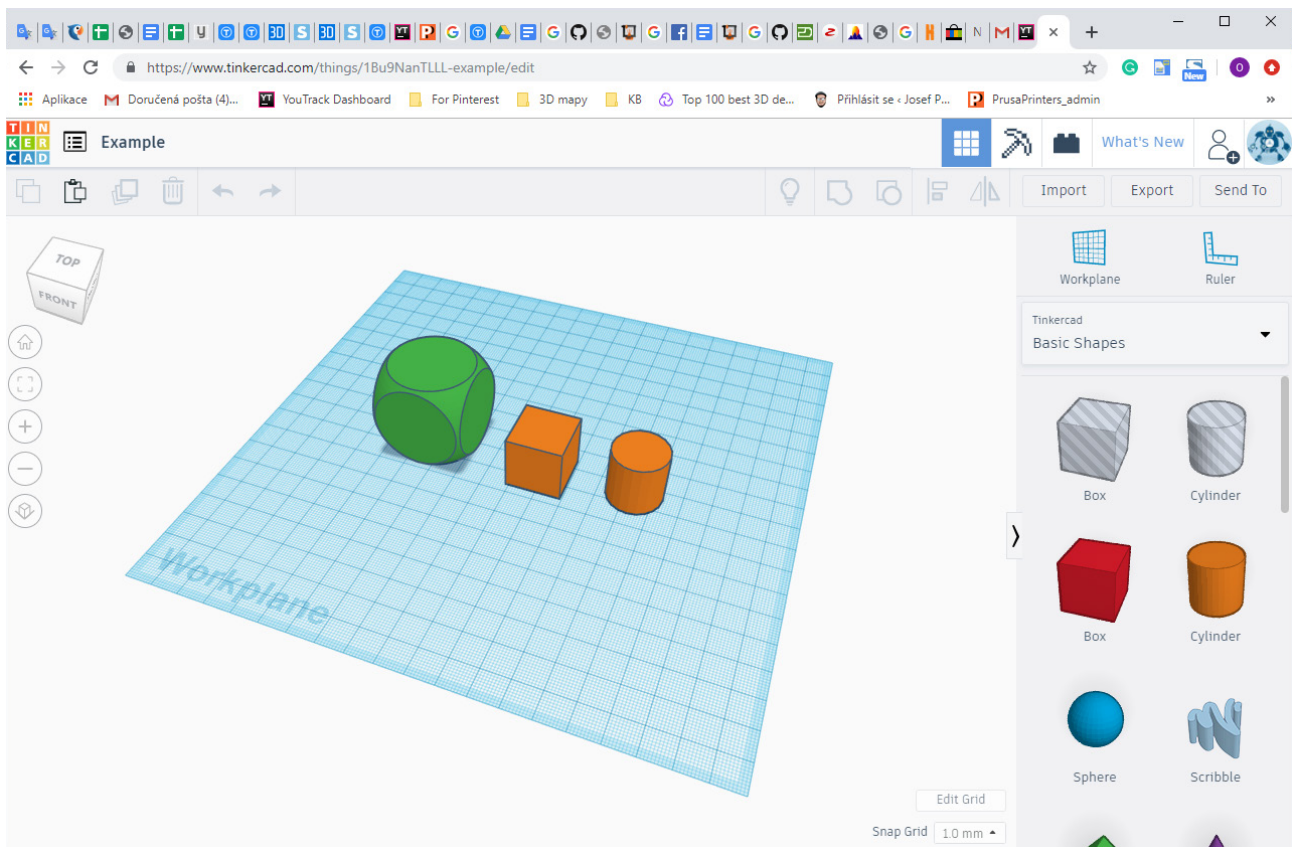

Autodesk Fusion 360

If you want to start designing more complex objects, or even various components that should fit together, then you need to select a more professional tool. Fusion 360 is a popular option. Users can work in both CAD (Computer-aided Design) and CAM (Computer-aided Manufacturing), strength analysis or visualizations. Fusion 360 offers not only parametric modelling, but even sculpting as well. Let's take a look at these two methods more closely.

Parametric modeling is a common way of creating structural models or mechanical parts. The object starts as a 2D shape using basic primitives (such as a line, square, rectangle, point...). Next, the object is extruded, which turns it into a 3D shape.

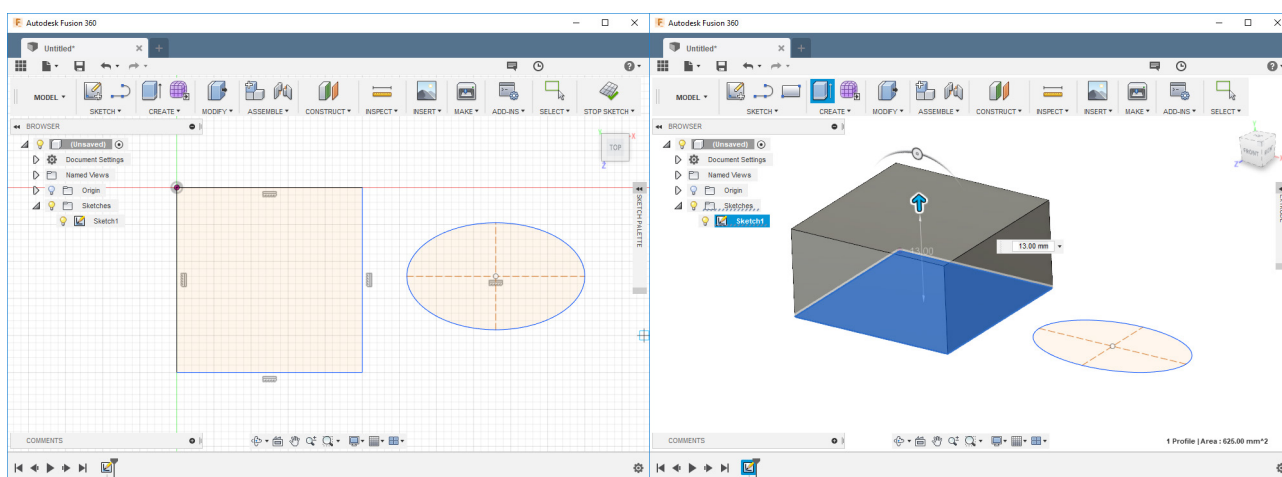

Now, imagine that we want to create a model of a dog. Using parametric modeling is inefficient and too complicated, because we want to create an organic shape. This is where sculpting steps in. Digital sculpting is somewhat similar to real-world sculpting (e.g. using a sculpey or similar material), however it has many advantages - such as the undo function. The primitive objects in this case are already 3D objects - cube, sphere, cylinder, toroid and others. These objects can be freely extruded, squished, bent... See the pictures below.

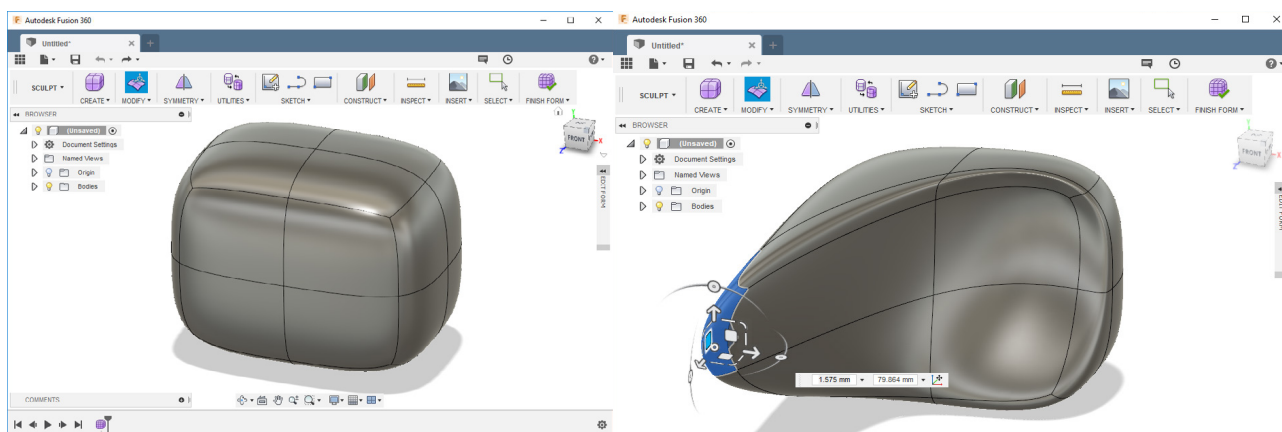

Fusion 360 is becoming more and more popular also thanks of the fact it's free to use for makers, innovators, enthusiasts and small companies with a turnover of up to 100,000 USD a year. If this program caught your attention, go right ahead - it's a great tool with an active community around it. Plus, you can find tons of tutorials online. Head to www.autodesk.com/products/fusion-360 and download the app for

Blender

Blender is probably the best free 3D modeling tool available today. It's developed under an open-source license and it's available for Windows, Mac and Linux. It may be a bit too complex for a beginner, chaotic even. However, it has found its way into the hearts of many users. Especially users with artistic ambitions, who don't need precise parametric modeling, found Blender to be an amazing tool. Sculpting, texturing, animations... Blender is a Swiss army knife among 3D modeling applications.

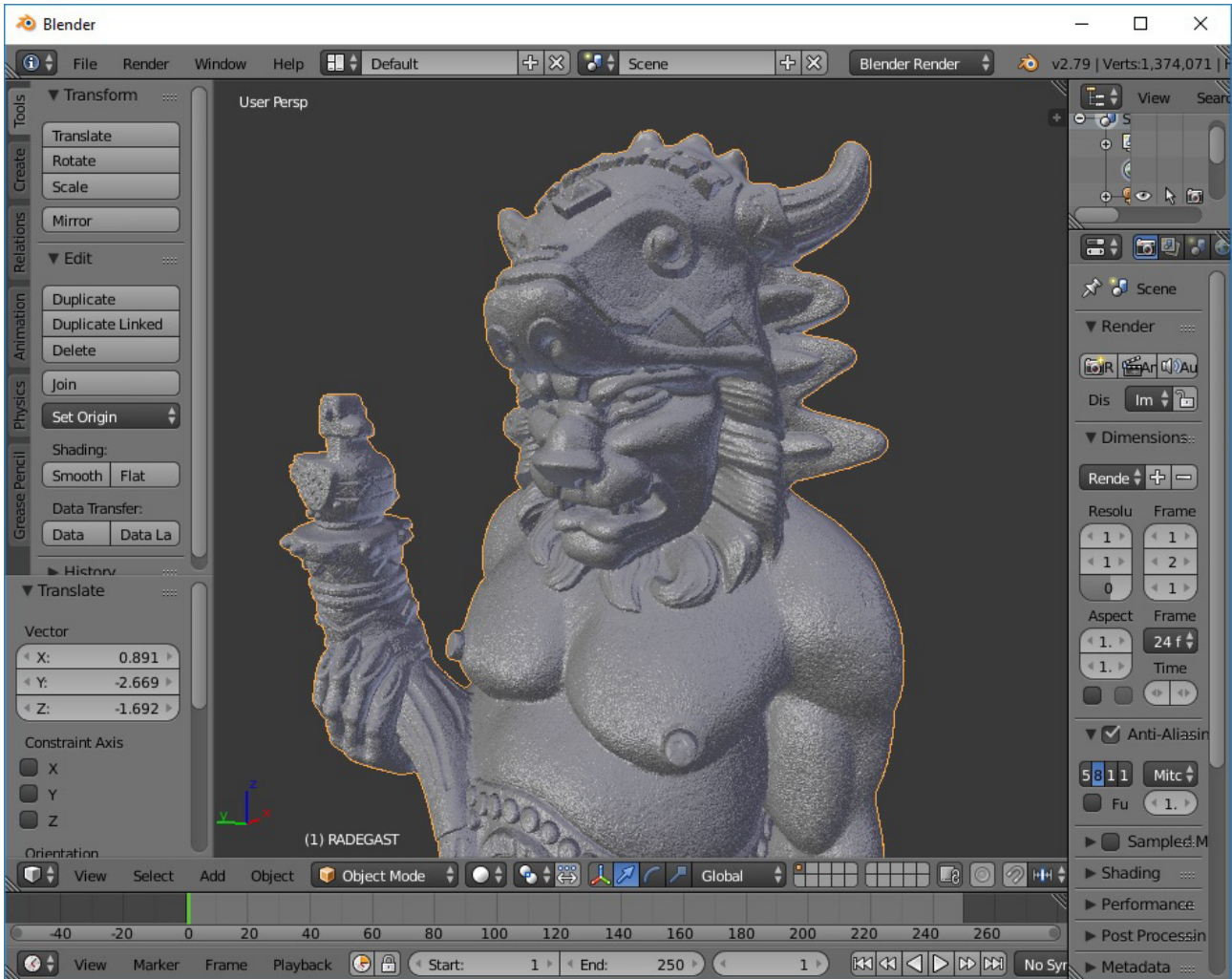

OpenSCAD

OpenSCAD is an open-source project available for free from www.openscad.org. It takes a completely different approach to 3D modeling - everything is done by writing code. The user interface is divided into two parts. In the left section, the user defines 3D objects by 'programming' them, while in the right section, a 3D preview is displayed. The application works mostly with a couple of primitives (cube, cylinder, sphere,...) and basic boolean operations (join, cut, intersection). However, the program also allows for advanced scripting - you can use commonly known operators, such as if, while, for, logical operators and others. If you feel you are more of a programmer than an artist, you may give OpenSCAD a go.

How to start with creating models in OpenSCAD is described in detail at:

blog.prusaprinters.org/openscad.

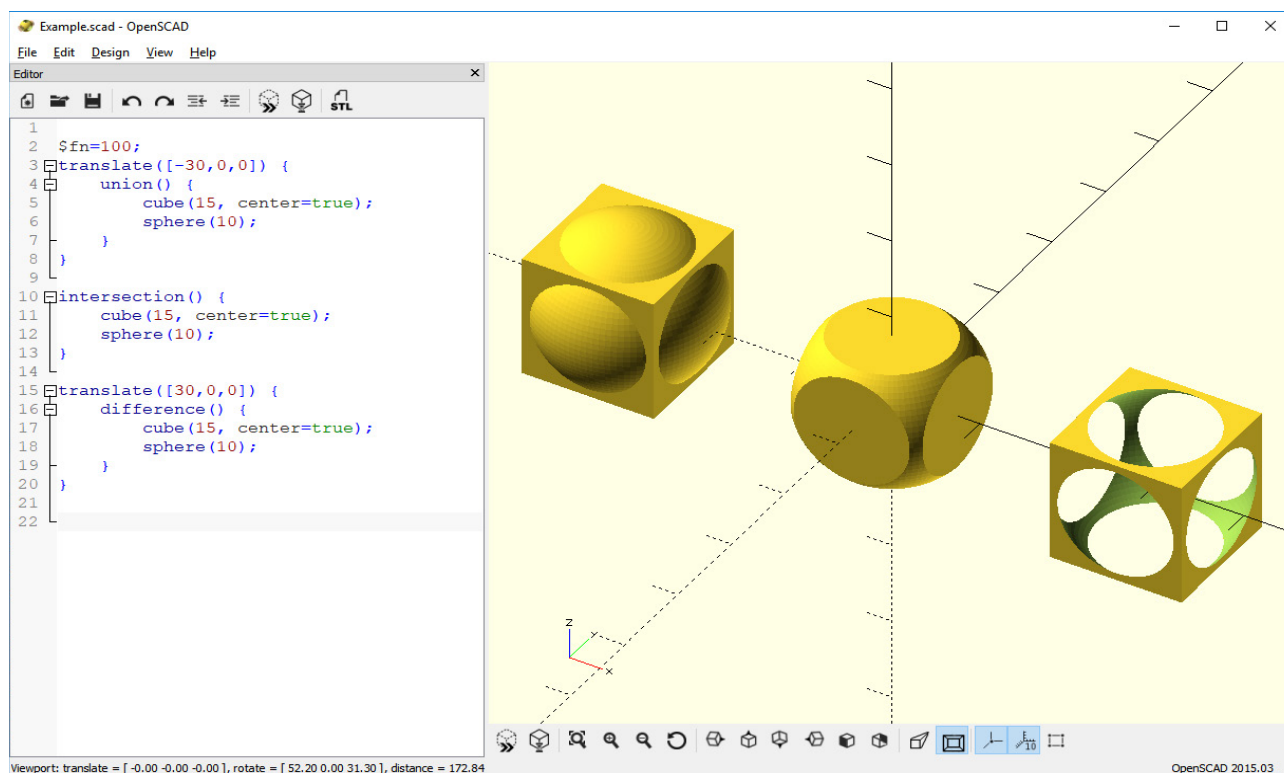

You can also try the following applications:

- Microsoft 3D Builder
- Meshmixer
- Rhinoceros 3D
- FreeCAD
- Autodesk Inventor
- SolidWorks
- Autodesk AutoCAD
- SketchUp

Things to keep in mind when designing a model

1. Try to minimize the need for supports. 3D printers can't start printing mid-air, and massive overhangs require supports as well. To save time, material and improve the quality of the object's surface, try to design the object in a way that will minimize the need for supports.

Let's take a look at an example - you need to design a part of a fence and it's up to you how the pickets will look. In the pictures below, you can see two ways how to design the fence if we want to print it in a vertical position. The best solution here will be to print the part horizontally.

Model preview in Slic3r - support structures are marked green, while the object itself is yellow.

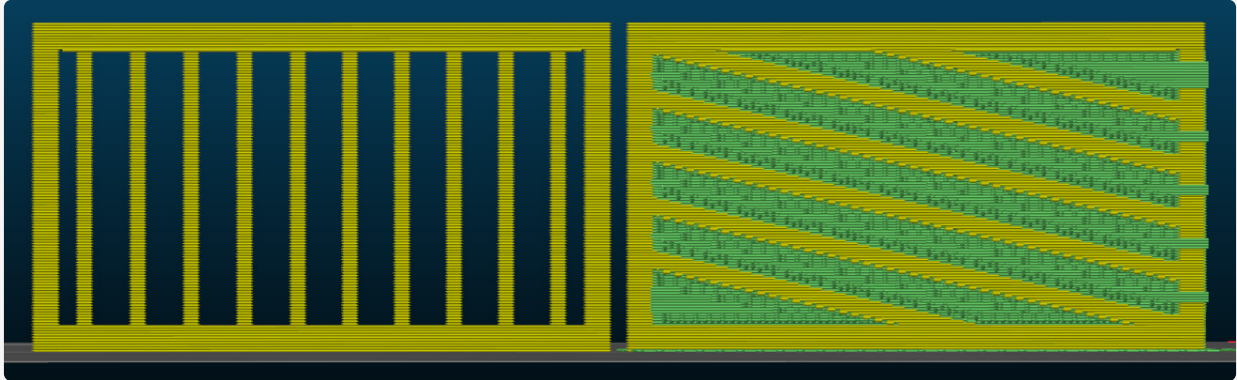

It's possible to print this model without supports.

Supports are required to print this model successfully. However, removing them will be difficult and the surface of the model won't be perfectly smooth.

2. Decide how the model will be positioned on the print bed. Surfaces placed on top of supports won't be as smooth as surfaces placed directly on the print bed.

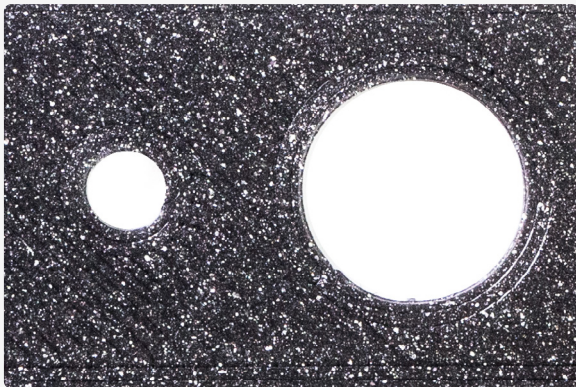

Surface printed directly on the print bed is perfectly flat and smooth



Surface printed above supports. The surface is inconsistent and rough. This is the worst case scenario for demonstration purposes. Surfaces with a lower overhang angle look much better even with supports.

3. The print has lower strength in the direction parallel to the printed layers than in direction perpendicular to the printed layers. If you expect that the printed part will have to withstand certain forces, keep this fact in mind.

4. Consider splitting the model into multiple parts, then find the optimal positions for these parts on the print bed. Let's take a simple sphere as an example. Printing it as a single part is quite difficult, because the initial layer that touches the print bed is very small. You can add a brim and supports to remedy this issue. However, the surface quality will suffer (see below). A possible solution is to cut the sphere into two parts. Print them separately and then glue them together.

Printing a sphere as a single object. The layers at the bottom of the object are affected.

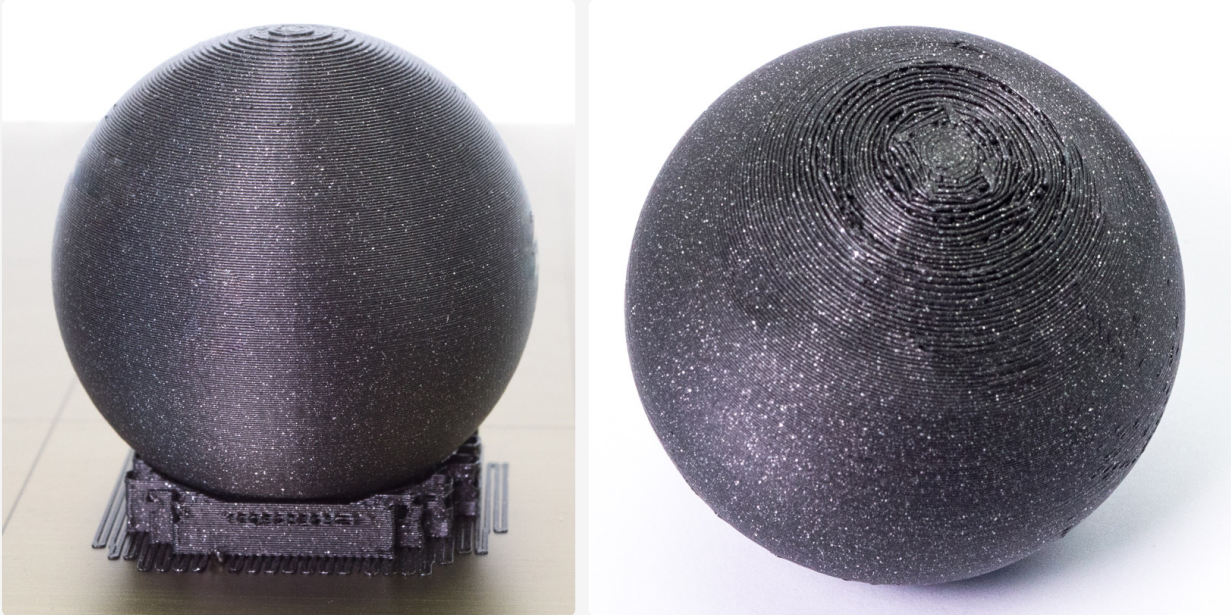

Printing a sphere cut into two hemispheres, which are then glued together.



5. When modelling parts that should fit together, you need to include a certain tolerance. You won't be able to combine two parts with zero-tolerance dimensions. Please keep in mind that you will probably have to tweak the tolerances until you reach an optimal result. There's no single "universal" value - it all depends on the size of the model, horizontal or vertical orientation, shape of the parts that should interlock, calibration, settings, materials and other aspects. So don't worry about not nailing it the first time, it will take a couple of tries to tweak everything - after all, 3D printers are designed to be great prototyping machines, so keep iterating until you find the best result. A quick example: If we want to insert a 10mm rod into a tube, the tube's diameter should be about 0,15mm bigger.

6. A circular hole printed vertically won't be perfectly circular. To achieve a better result, print circular holes horizontally as depicted in the pictures below.

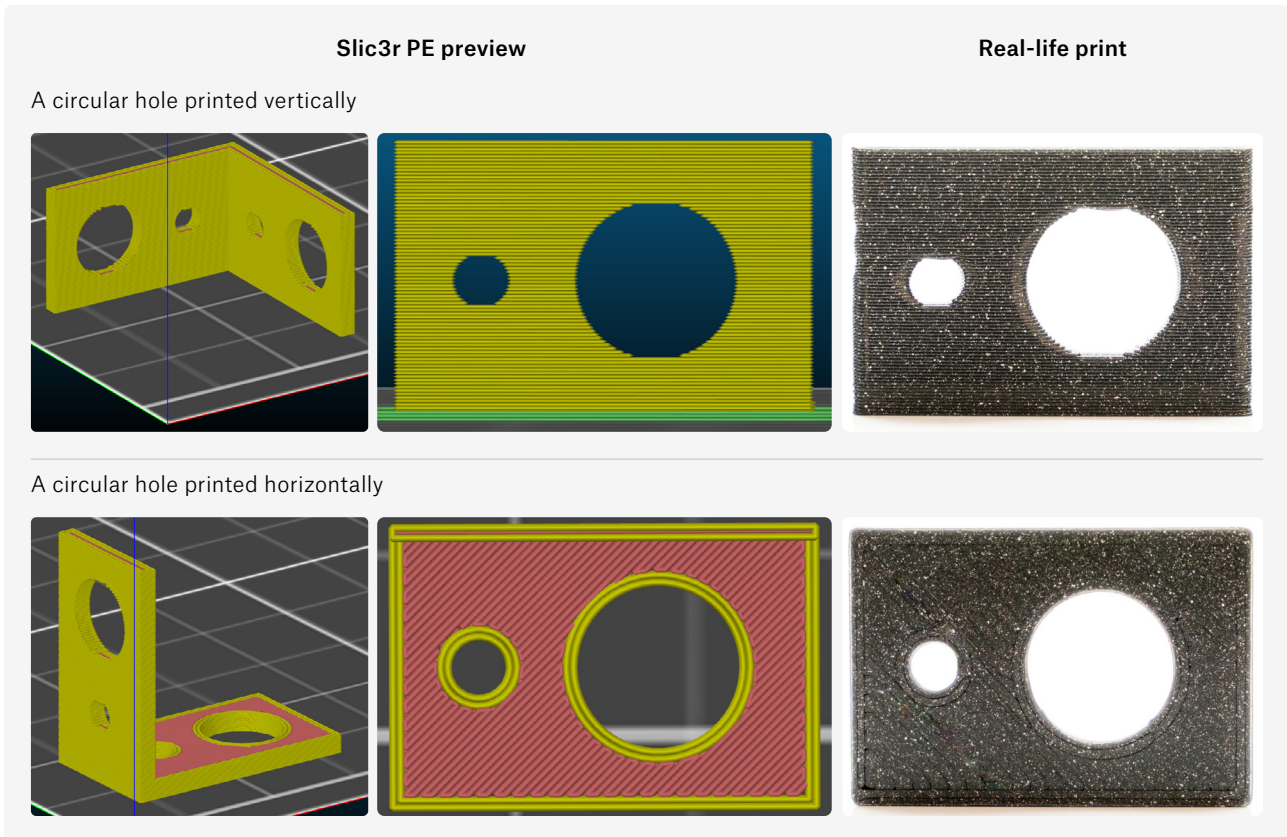

7. The width of a single perimeter when printed with a standard 0.4mm nozzle is about 0.45mm. This affects the total width of a model's walls.

Wall thickness	Is it possible to print?
Less than the width of one perimeter	✗
One perimeter	✓
More than the width of one perimeter, but less than two perimeters	✗
More than twice the width of one perimeter	✓

Examples of possible object orientations and how they affect the resulting prints

Let's take a look at a simple L-shaped clamp with two holes on both ends and how the object orientation affects its final look. And it's not only the looks that are affected - the way how an object is oriented has an effect on its structural integrity and toughness as well.

- ⊕ The side parallel to the print bed will have nicely shaped circular holes.
- ⊖ Way too many supports result in a lot of wasted material.
- ⊖ Low material strength in the 90° corner.
- ⊖ The part printed vertically will have a tendency to break in the direction of printed layers.
- ⊖ The part printed vertically won't have perfectly circular holes.
- ⊖ The part above supports will have a slightly rough surface.

Slic3r preview

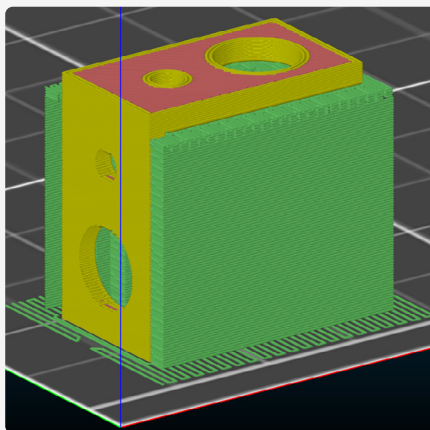

Printed object



This is not an optimal orientation for this model

- ⊕ The side printed parallel to the print bed will have nicely shaped circular holes.
- ⊕ No supports.
- ⊖ Low material strength in the 90° corner.
- ⊖ The part printed vertically will have a tendency to break in the direction of printed layers.
- ⊖ The part printed vertically won't have perfectly circular holes.

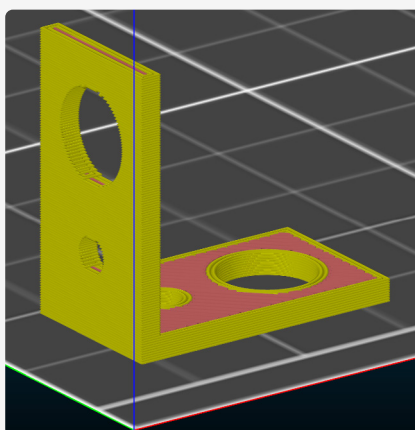

This is not an optimal orientation for this model

- ⊕ Best possible material strength in the 90° corner.
- ⊕ No supports.
- ⊖ The holes won't be perfectly circular.

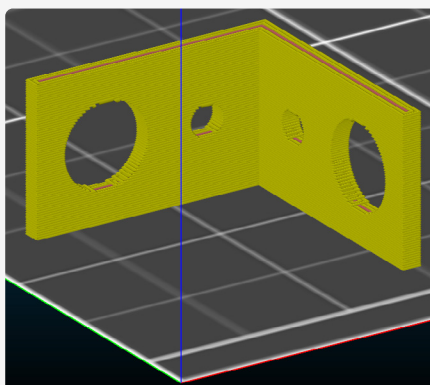

This is the optimal orientation for this model

3D Scanning and Photogrammetry

3D scanning and Photogrammetry are two popular options for creating a digital object based on a real one. 3D scanners have been on the market for quite some time, but their high price makes them unavailable to mainstream users. The cheapest scanners can be bought even for less than 300 USD, while the expensive ones can go well beyond 10,000 USD. That's where photogrammetry steps in. It's a much cheaper technology, however, it requires some extra work – the whole principle is based around processing dozens, or even hundreds, of photographs of a single object in a specialized software. The good thing is that even your smartphone's camera is enough for the job. You can learn more about photogrammetry at: blog.prusaprinters.org/photogrammetry.



Choosing the right printing material

A common misconception is that various filaments are just about different colours. The truth is that there are many different types of filaments with greatly different properties. Some materials are very easy to print and allow for plenty of detail on the printed objects, but their heat resistance is low (PLA). Other materials can be the complete opposite (ABS).



You can read more about printing materials in the 'Filaments' chapter.

Slicing

Slicing is the process of turning a 3D object into a machine code called G-code using a software tool called a slicer. The most common slicers are Slic3r PE (and its successor PrusaSlicer 2.0), Simplify3D and Cura. The input for the G-code generation is not just a 3D object, but various settings come into play as well. They can affect the G-code / printing process in a number of ways – like the toughness of the model, amount of details or printing speed. It's also possible to modify the objects - scaling, rotating, cutting and other tools are available. Last, but not least – you can use slicers to position the object(s) on the virtual printing surface. The software is as important as hardware, meaning that correct slicing settings are crucial for a good-looking 3D print.

There's a number of available slicers, each of them has its pros and cons. Most of them are available for free. Beginners should stick to slicers that feature tested pre-made slicing profiles for their printers. Once you become comfortable with something that works out-of-the-box, you can download other software packages and try experimenting. Pretty much every major 3D printer manufacturer has its own slicer fine-tuned for their printer lineup. Let's take a look at three slicers that are used by Original Prusa i3 owners the most.

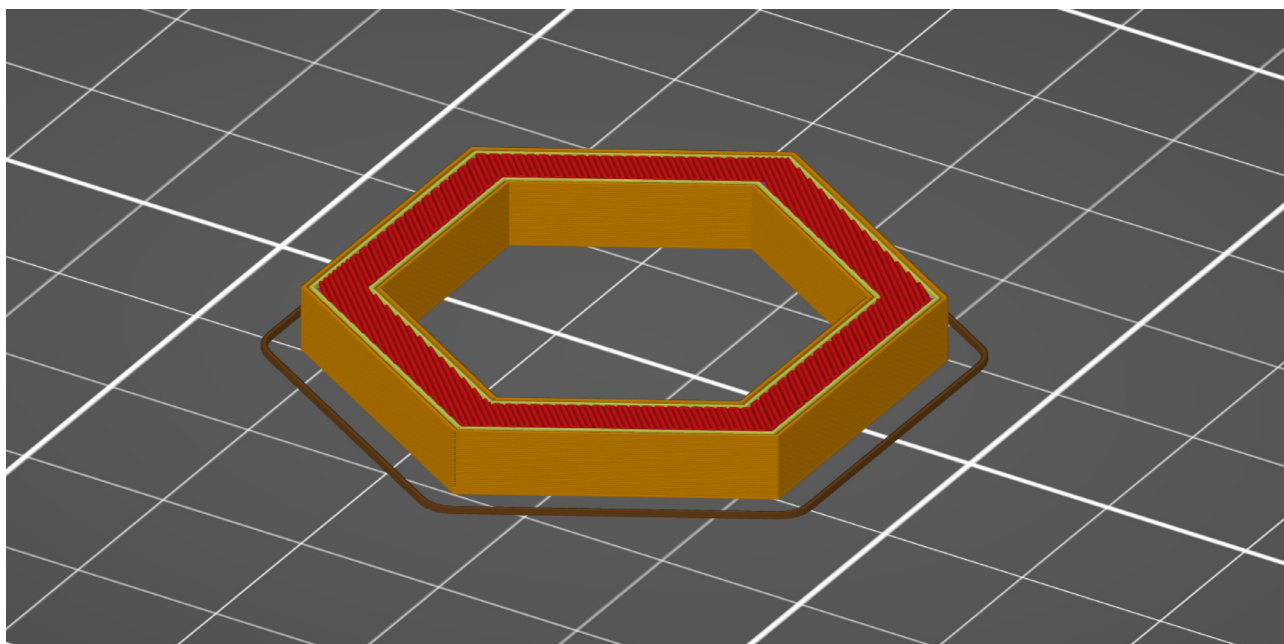

PrusaSlicer

PrusaSlicer is based on, or rather 'forked from', the open-source Slic3r project. PrusaSlicer is our default slicer that also comes bundled in our Drivers & Apps package. The application features a number of useful features and is regularly updated. It has plenty of improvements and optimizations for Prusa Research products including profiles for multi-material printing. And it also comes with a huge library of pre-made and tested settings for all sorts of materials. It's a great option for every Original Prusa 3D printer owner.

Features:

Free and Open-source.

- Features over 30 tested profiles for various filaments, ranging from the most popular ones to various exotic materials (such as Woodfil and many others). Print profiles are regularly updated.
- Built-in firmware flashing tool for Original Prusa 3D printers.
- Multi-Material printing support.
- Octoprint integration.
- Plenty of options for print settings, including special area-based modifiers.
- Sliced model preview that shows the object layer-by-layer.
- Variable layer height settings.
- Support for SLA 3D printers
- Tree supports generation

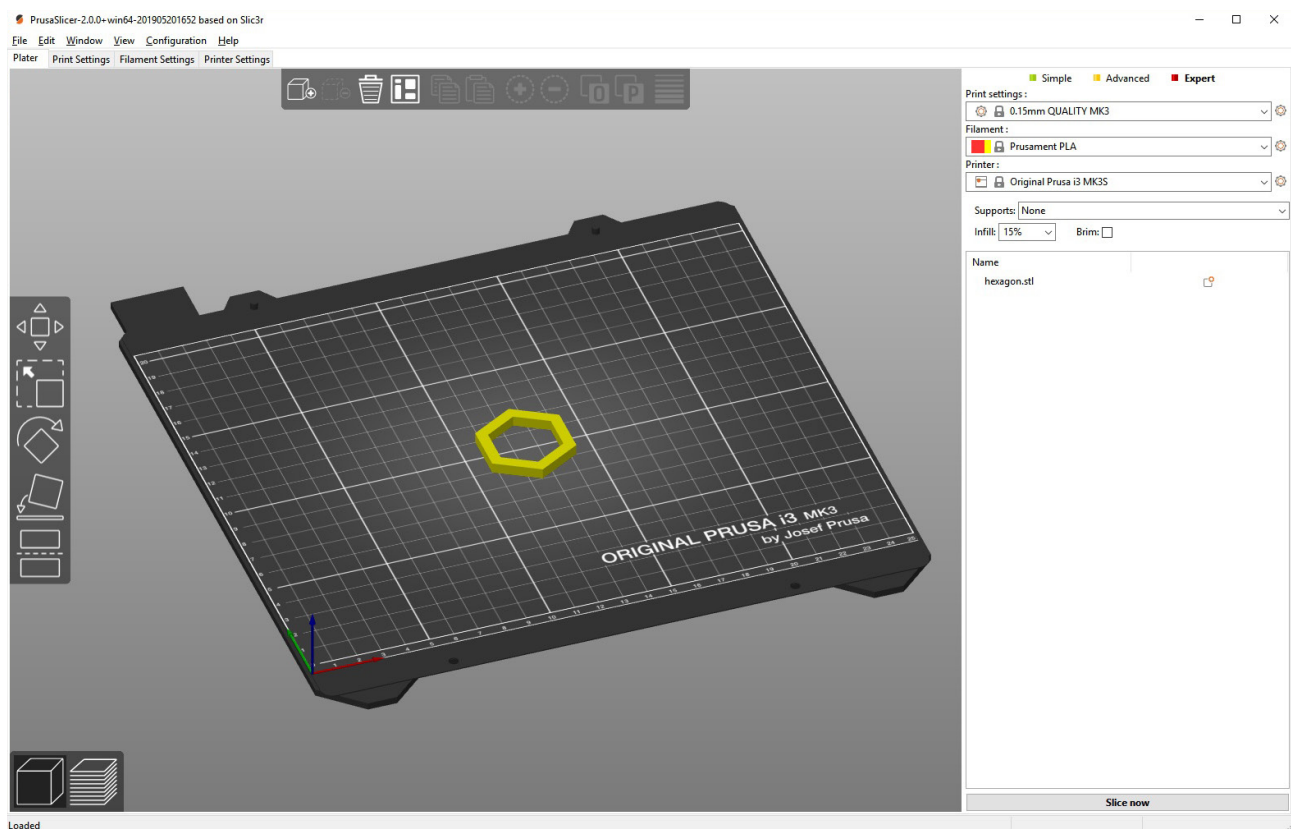

Simplify3D

Simplify3D is a slicing software developed independently - so it's not tied to any 3D printer manufacturer or specific model. It features pre-made profiles for hundreds of various 3D printers. This is especially useful if you have more than just one brand of 3D printers, since you don't have to create printing profiles yourself.

Features:

- 📦 **Paid software (149 USD).**
- ➡ Realistic simulation of extruder movements in the preview mode.
- ➡ Preview of sliced 3D objects in G-code format.
- ➡ Automatically generated 3D supports with optional user modifications.
- ➡ Plenty of print settings.
- ➡ Area-based settings modifiers, object-specific print settings.

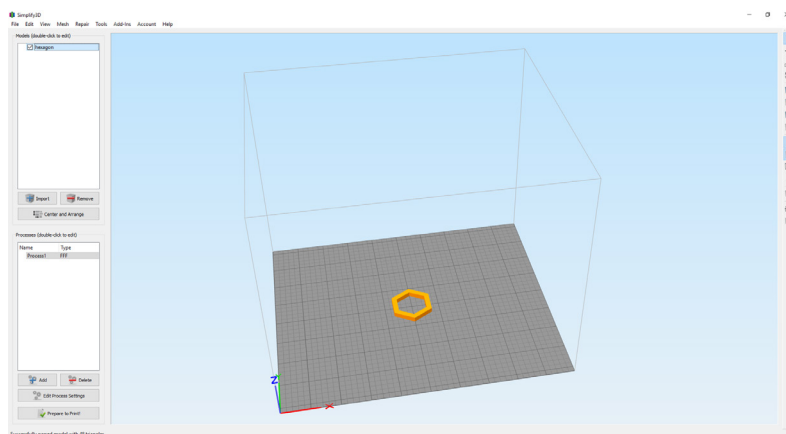

Cura

Cura is a slicing software developed by Ultimaker, a 3D printer manufacturer. It's the most common choice for owners of Ultimaker 3D printers. However, the program features a number of profiles for other brands of 3D printers as well.

Features:

- 📦 **Free and Open-source.**
- ➡ Simple interface is beginner-friendly, however, there are advanced settings as well.
- ➡ Optimized profiles for official materials and Ultimaker 3D printers.
- ➡ Object-specific printing settings, allowing to position multiple objects on the same print bed, each with different configuration.
- ➡ Preview of a sliced 3D model in G-code format.
- ➡ Shows a detailed breakdown of how long it will take to print each section of the model (perimeters, supports, infill and others).

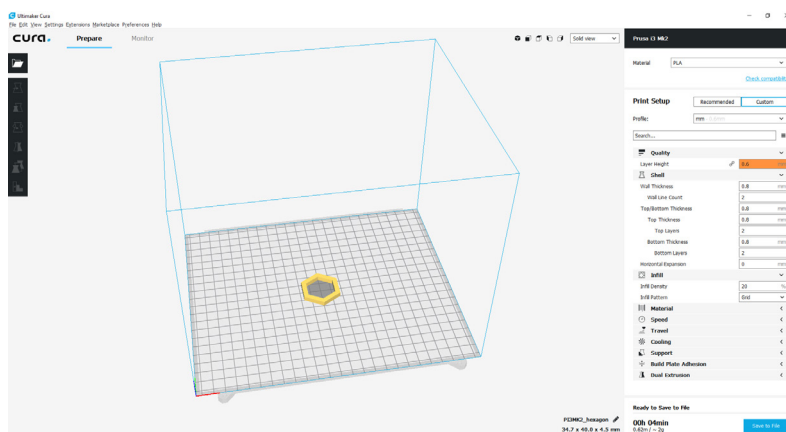

Slicer – basic settings

Filament and print bed temperatures – every filament manufacturer states the optimal temperature range for their filaments. You should stick to the recommended values. Modification of print temperatures leads to changes of the print's visuals. The temperature of the nozzle and print bed usually ranges from 200°C to 240°C and 60°C to 100°C respectively.

Layer height – sometimes also called the “Z-axis resolution” has a major impact on both print times and overall surface finish of the printed object. Higher values lead to faster prints and more visible layers on the surface of the object. This effect is especially prominent on surfaces that are nearly parallel to the print bed. Most of the time, layer heights of 0.15mm - 0.20 mm are preferred. Lower layer height leads to more detailed prints (less noticeable layers), however, the printing time is extended. PrusaSlicer has a function for configuring variable layer height - it means users can choose which parts of the object will have lower layers (detailed or sloped parts) and which parts can have increased layer height.

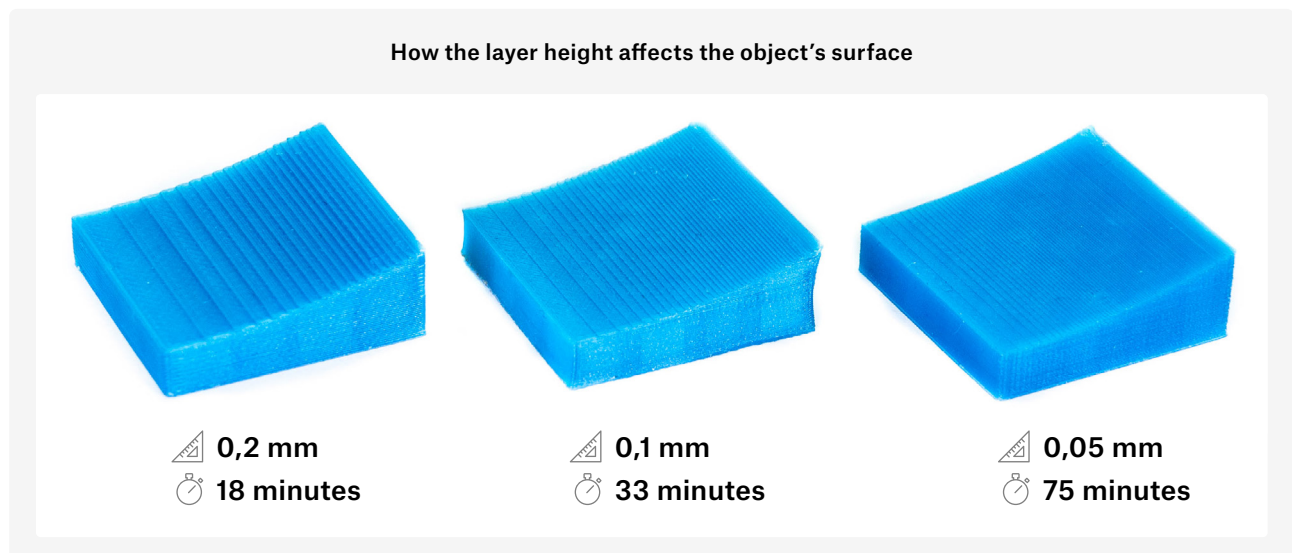

Vertical shells / Perimeters – these are the outside walls of the model and by setting the Vertical shells, we're adjusting how many perimeters there will be. The resulting thickness of the wall can be roughly calculated as: number of perimeters × nozzle diameter. You can learn more about perimeters in our guide at blog.prusaprinters.org/perimeters..

Horizontal shells / Solid Layers – used to configure the number of top and bottom layers of the model, which will be completely solid (100% infill).

Infill – affects the print time, durability of the printed object and filament consumed. Infill is set as a percentage, while 0 % means a completely hollow object. Usually, 10-20 % is used. It's also possible to choose the infill pattern (see below).

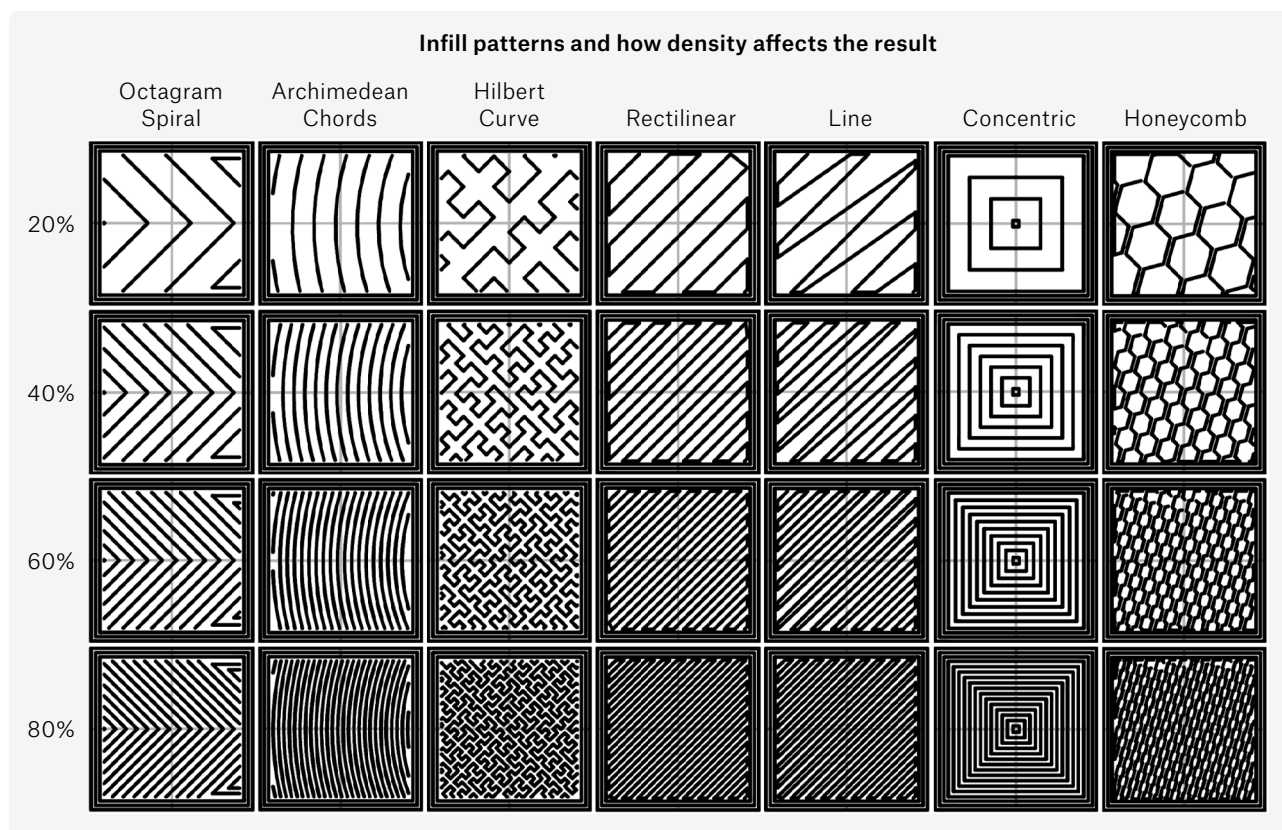

Supports – scaffolding-like structures that support overhangs or parts that start mid-air. Supports are designed to be easy to remove, but they may leave marks on the model. Our goal is to minimize the number of supports by rotating (or even designing) the object to achieve an optimal orientation, where only a few (or none) supports are required. Fewer supports means faster printing and better overall look of the model.

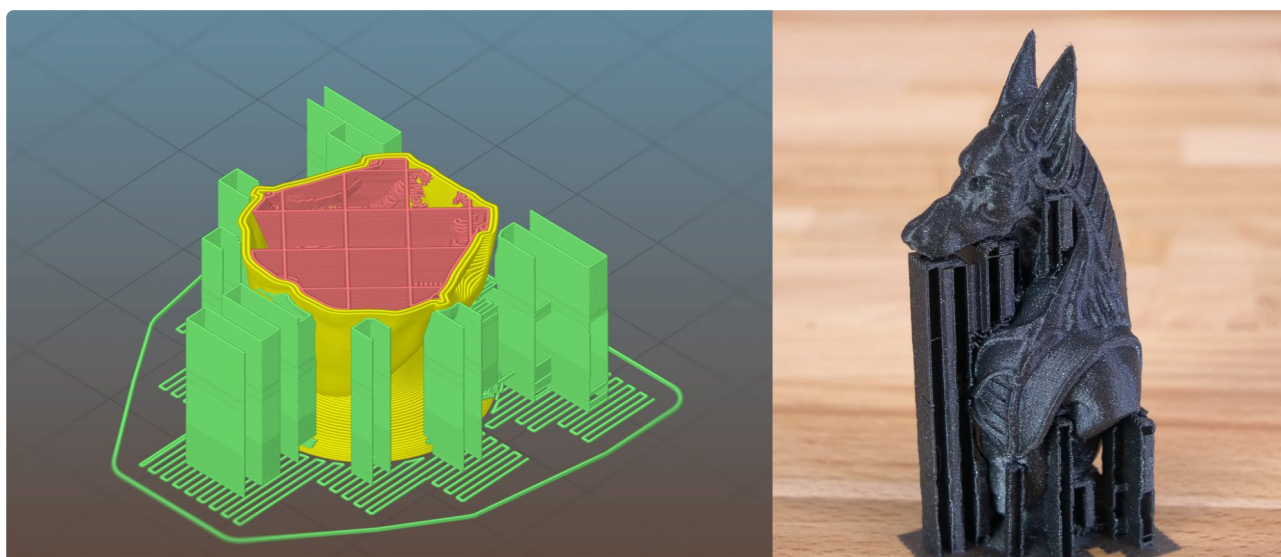

Bridging – this is the only case when the printer can print in the air with no supports underneath the layer. This is a special case, though. The extruder can drag a string of extruded plastic in a straight line between two solid points. This also means the bridge has to be perfectly parallel to the printing platform. The maximum length of the bridged path is also determined by the cooling performance of your 3D printer.

Brim – to increase the adhesion of the printed object to the printbed (e.g. when printing small/thin objects), it's recommended to use a brim. It's an additional flat surface that will prevent the object from warping/detaching mid-print. It can be easily removed when the print job finishes.

Skirt – unlike the Brim, the Skirt does not touch the object. It's a thin wall around the printed object and it usually has more than one layer. It's been most commonly used when printing ABS, which has a tendency to shrink and crack as it cools down. The added skirt creates a micro-clima, which helps to block circulation of cool air. Another use for the skirt: you can inspect it to check whether the first layer is adhering well and adjust the Live Z value in case it's not.

Raft – a special kind of support structure, which lifts the whole printed object above the printing platform. It is used primarily with ABS materials, because it helps to prevent warping / lifting the object from the print surface.

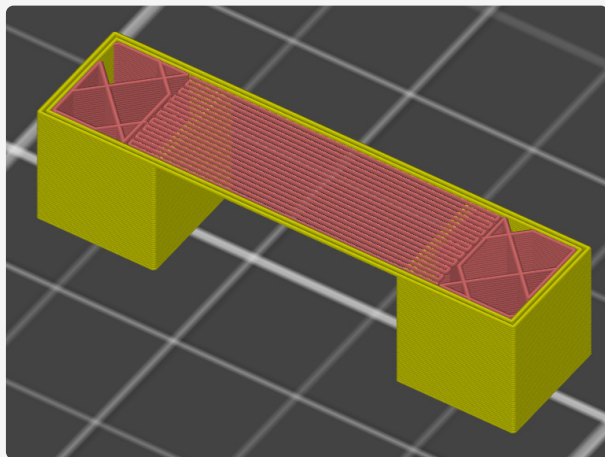

Bridging

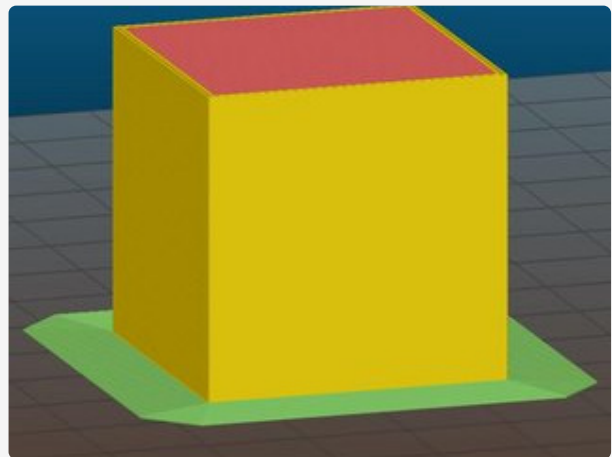

Brim

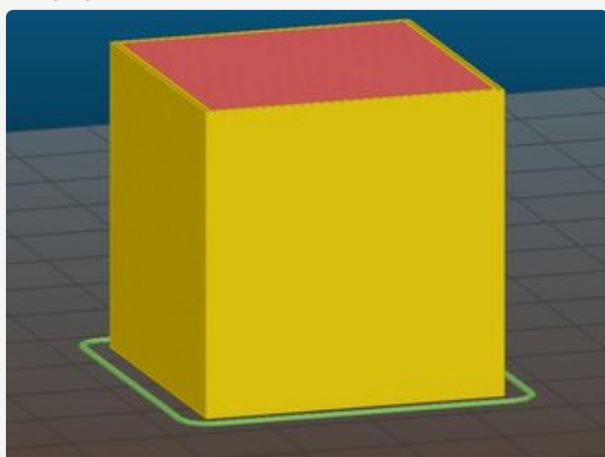

Skirt

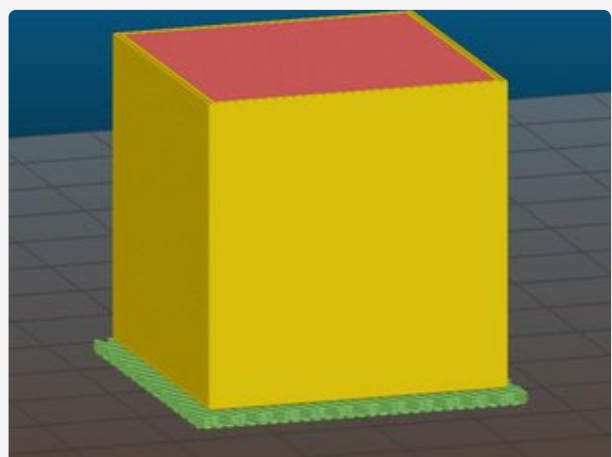

Raft

Cooling – it's recommended to actively cool printed objects - especially thin and tall structures, which don't have enough time to cool down on their own, because the extruder tends to stay in one area for extended periods of time.

Advanced settings

Slicing apps offer a whole range of other parameters you can tweak and tune: speed for perimeters, bridges, infill and many others. These settings are usually factory tweaked by default, so there's no need to adjust them further.

You can read more about slicing in our article at blog.prusaprinters.org/slicer.

Preparing the print surface



Preparing the print surface is key for successful printing. If the printer is not properly calibrated, and the surface does not allow for good adhesion, the print job will fail. Always make sure the first layer sticks to the printing surface well.

The development of 3D printers included also various versions of the print surface. Originally, there were only standard glass or mirror print beds without additional heating. To increase adhesion, ABS juice (tiny bits of ABS dissolved in Acetone) were used. Other options were to use a kapton tape or paper glue (Kores). This also meant that working with the printer had been somewhat messy. Then, the PEI film was discovered - and everything changed. You can find the PEI surface on all Original Prusa i3 3D printers starting with the MK2 version. This type of surface does not need lengthy and complicated preparation - just keep it clean and degreased. It's compatible with a wide range of materials and the only time when you need to use the Kores glue is when you want to print with PET. In this case, the glue acts as a separator, because PET's adhesion may be way too strong, which makes it difficult to remove from the bed.

Starting the print

Starting the print means sending the generated G-code into a 3D printer. Let's take a look at available options.

During the whole print job, the printer needs to have sequential read access to G-code instructions. If, for whatever reason, the 3D printer is unable to read the G-code, the print inevitably fails. This is why using an SD card or a USB drive (or similar device) is recommended - the drive is present in the 3D printer at all times and the printer can read the data from it without interruptions. As an alternative option, there's a possibility to connect the printer directly to a PC using (usually) a USB cable. A special application, such as Pronterface, then feeds the data from the PC into the 3D printer, even for several hours in case of long prints. A huge disadvantage lies in the fact that the computer needs to be running during the whole process a number of things can go wrong (sleep / hibernation, restarts, app crashes etc.) and the process will be interrupted, resulting in a failed print job. Direct connection to PC is not recommended.

However, it's still possible to reliably use a PC for this task - a small PC, such as Raspberry Pi with the Raspbian operating system. This development board is cheap and available pretty much anywhere, and it can run the Octoprint app, which is a free 3D printer controlling app. Octoprint offers remote control, system monitoring, webcam support and many other things - all accessible through a web browser UI.

Post-processing

3D printed objects are usually ready to be used once you finish printing - this applies to functional parts mostly. If you have extra requirements about the object's surface or the overall look in general, you need to adjust the surface using a variety of tools. This is called post-processing.

Post-processing covers a wide range of techniques, materials, tools and procedures with the aim to make the surface of the printed object smooth, colored and good looking in general. Models made of plastics can be sanded (using electric sanding machines usually leads to damage to the model due to high temperatures created by excessive friction), smoothed out with putty, sprayed with a filler, laminated, colored with acrylics or with a spray... However, adding extra material on the model can cause tiny details to disappear.



You can learn more about post-processing in our article at: blog.prusaprinters.org/postprocessing.



Gluing and smoothing models using acetone

ABS and ASA are materials soluble in acetone. This can be also used to glue printed models together: smear the surfaces you want to attach with a bit of acetone and push them together.

Acetone can be also used to smooth the surface of 3D printed models. You can either submerge the model into acetone for a short period of time (5-10 seconds), or you can place the model in a sealed container with acetone on the bottom - the object won't touch the surface, but the vapors will smooth out the surface over time.

Smoothing out the surface leads to the loss of tiny details.

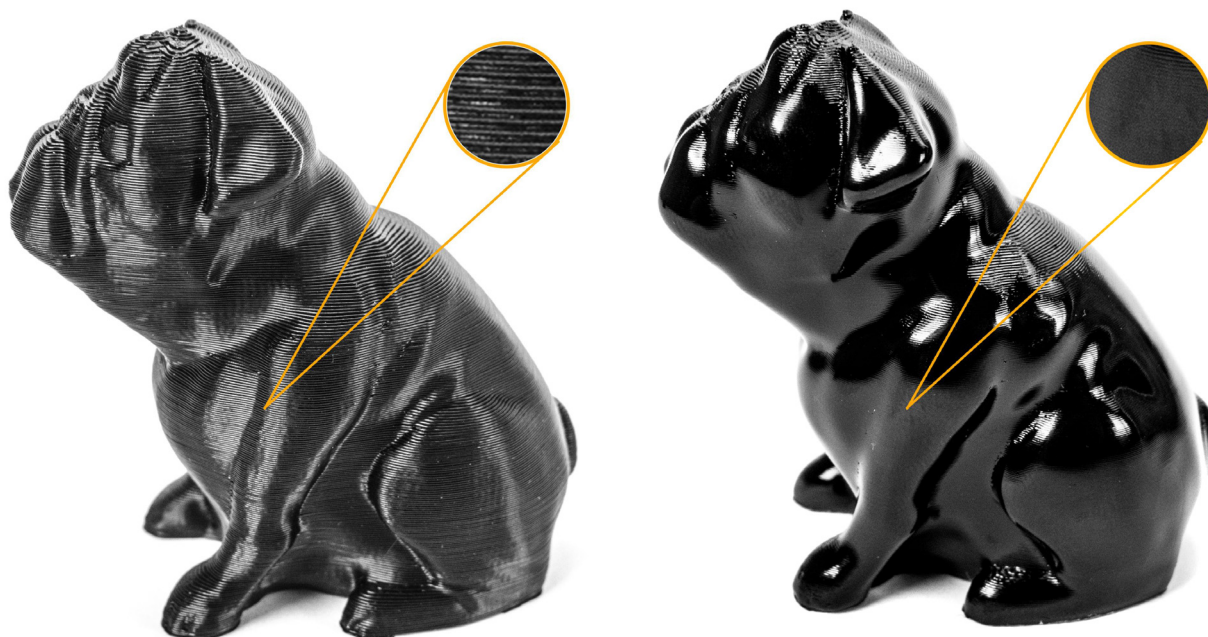

WARNING!

Acetone is a volatile flammable liquid - make sure the room is well-ventilated. Use protective gloves and glasses.

More tips:

- ⇒ So-called 'stringing' (thin strings on the surface) can be easily removed with a heat gun - however, do it very quickly, otherwise the object could deform in excessive heat.
- ⇒ Materials such as PLA and PETG can be glued together using any good superglue. You can use an activator to speed up the process.



PLA is a material soluble in chloroform (trichloromethane). However, chloroform is not suitable for smoothing out the printed objects (like ABS/Acetone combination), because it eats away the surface. Chloroform can be used as a glue to bond parts together, but a common superglue is a much better option. Chloroform is a hazardous substance and it should be handled with caution and in well-ventilated areas.

FILAMENTS

As the popularity of 3D printers grows, manufacturers are also producing new filaments with various colours or special properties. Currently, the range of available filaments is pretty wide and there are plenty of materials to choose from: easily printable and very popular PLA, universal PETG suitable for printing of mechanical parts, very tough and temperature-resistant ABS, composite materials that imitate the look of wood or bronze, glow-in-the-dark filaments, soft flexible materials and many others.

Every filament needs specific print settings, which also means that the same type of material from two different manufacturers can have different printing requirements. It's even possible that there can be a filament from a single manufacturer that has different printing requirements based on its color (e.g. red vs blue PLA).

To reach the best possible quality levels during printing, always refer to the recommended printing temperatures set by the manufacturer. Only in case the prints have visible issues, you can start tweaking the material profile in PrusaSlicer – this includes temperatures, fan speeds, printing speed, filament flow, retractions and other settings.

The most frequently used filaments are PLA, PETG and ABS. We'll explain how these materials differ and in what situations they perform the best. But there are also other interesting materials on the market – in fact, there are so many materials that the best way how to learn more about them is visiting the manufacturers' websites.

If you are a 3D printing beginner, the most important thing you should start with is to familiarize yourself with the "basic" materials and learn in which situations they perform the best. The most user-friendly material is PLA. Let's consider PLA filaments the baseline for our guide and see how the other popular materials compare.



PLA

PLA is likely the most used filament in general.

There's a couple of reasons why:

- ⇒ It's easy to print. What does it mean in reality? Very nice surface finish and acceptable surface finish above supports and in large overhangs. Good for printing small and detailed models.
- ⇒ No unpleasant odor during printing.
- ⇒ Low thermal expansion compared to other materials. It does not warp, and sticks to the printing platform nicely. This is why it's suitable for printing large objects.
- ⇒ PLA comes in a wide variety of colors.
- ⇒ One of the cheaper materials.

So why do we need other materials?

- ⇒ PLA is hard and brittle. It has a tendency to break and shatter under pressure.
- ⇒ PLA is not temperature-resistant, it starts to soften at around 60°C, which makes it a less-than-ideal choice for printing things like car smartphone holder.
- ⇒ Compared to the rest of popular materials, PLA has the worst weather-resistance.

In these three situations, PETG and ASA are better choices.



PETG, ASA and ABS

All these three materials are more flexible compared to PLA, which means that they will flex slightly under pressure and won't break immediately. On the scale from the easiest to the most difficult materials to print, PETG sits between PLA and ASA/ABS. The problem with ASA and ABS is their thermal expansion. These materials tend to bend and warp during printing, which causes them to detach from the print bed - especially larger objects have a higher tendency to warp and bend, making them more difficult to print. Also, ASA and ABS produce a very noticeable odor during printing, much stronger than PETG or PLA. Also, compared to PLA, PETG has a shinier surface finish, but also a tendency to create filament strings during extruder movement.

What are ASA / ABS good for and what's the difference between them?

ABS was the first widely available material for 3D printing. As the industry evolved, new and improved materials appeared on the market. ASA is considered to be the successor to ABS. Most of their properties are the same, while ASA is better in some ways. ASA is a UV-stable material and it also has lower thermal expansion, which makes it easier to print (compared to ABS).

Another thing worth mentioning is that prints from ABS and ASA can be smoothed out using acetone vapours.

And that covers PLA, PETG, ASA and ABS - these are good materials for 3D printing in general. You might want something extra, though. Let's take a look at some materials that are used less often, but they offer some interesting features - their price tends to be higher, though.



FLEX

Flexible materials are a large group of special filaments with flexible properties. These materials are somewhat similar to rubber - when you bend them, they won't break. Flexible materials are produced with different levels of hardness. The softer (more "bendy") the material is, the more difficult it is to print with it. Flexible filaments can be used to print wheels for RC models, cell phone cases, silentblocks. However, keep in mind that the printed objects don't have the same level of adhesion as rubber. In other words, for high performance RC cars, store-bought tires will perform better.



Composite materials

Composite materials (woodfill, copperfill, bronzefill and others) consist of the main plastic part and a secondary material in the form of powder. These filaments are interesting mainly because of their look, since they can imitate various materials. However, they are usually very abrasive - a hardened nozzle is recommended in case you plan to print with these filaments more often. Also, to print wooden composites, we recommend using a nozzle with a larger diameter (0.5 or 0.6 mm), otherwise the wooden powder can clog the nozzle. Printing parameters can differ based on the main plastic component used - be sure to use the recommended settings in PrusaSlicer, or if the profile is not available use the vendor's recommended settings.



Bronzefill and other metal composites

Polished Bronzefill

PVA and BVOH for soluble supports

Usually, when printing a model, the best practice is to rotate the model in such a manner that will minimize the number of supports. However, this is not possible at all times. In most cases, the supports are printed with the same type of material as the rest of the model - and eventually, when the print is finished, we can break them off. The surface above supports can often carry traces of the broken-off material, layers can be more visible compared to the rest of the object etc.

There are 3D printers that can print with two or more materials at the same time (e.g. our Original Prusa i3 MK3S with the Multi-Material Upgrade 2.0), which opens the possibility to use a different material to print supports: this is where soluble materials, such as PVA and BVOH, come in. Thanks to these materials, the support distance parameter (which is used for easier removal of standard supports) is no longer required, because we will simply dissolve the material in water. However, these materials are more expensive than standard filaments. It's possible to reduce the filament consumption by using the soluble materials on the 'interface' only (a couple of layers between supports from a standard material and the object itself).

BVOH and PVA materials work the best in combination with PLA, especially due to the similar printing temperatures. Both BVOH and PVA are water-soluble.

HIPS is a support material soluble in lemonsol and works the best in combination with ABS.

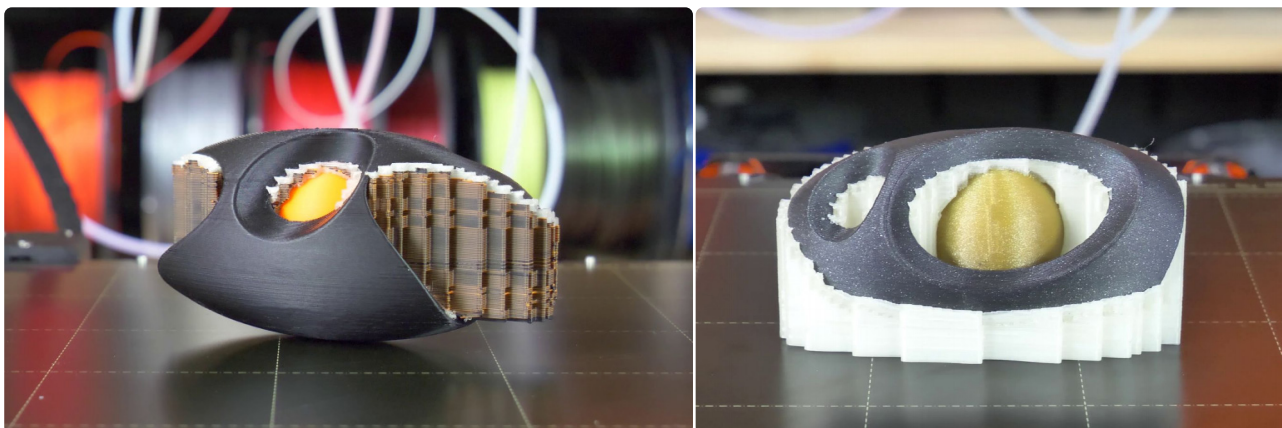

Other materials

PP – higher temperature resistance compared to ABS or PLA. Chemically resistant, flexible, has trouble sticking to the printing surface.

Nylon – resistant and tough material with great adhesion between layers. Nylon is friction resistant, so it's suitable for printing mechanical parts, but it's also hygroscopic (absorbs air humidity), which has a negative impact on printing.



PHOTOPOLYMERS / RESINS

Resins (also called Photopolymers or UV-sensitive resins) are printing materials for SLA 3D printers. Resins are liquids, which are cured (solidified) through exposure to UV light. Resins are usually noticeably more expensive than filaments, but their price can differ based on their properties. The cheapest resins can be bought for around 30 USD/L, while more advanced materials can cost as much as 400 USD/L - these are usually dental or casting resins. Generally speaking, SLA prints are more fragile than FFF prints. On the other hand, SLA prints don't break along layer lines - instead, they shatter like glass.

Resins usually consist of three basic components:

- ⇒ **The core** of the resin (monomers and oligomers).
- ⇒ **Photoinitiators** - molecules reacting to UV light, which initiate the solidifying process.
- ⇒ **Additives** - admixtures that change the color and properties of the resin.



When buying resins, always check at which wavelength the curing process happens to ensure a good compatibility with your 3D printer.

Resins are not differentiated based on the type of material, as is the case with filaments for FFF printers. Resin is essentially only one. Differences arise only through adding additives and dyes. A typical parameter that can be affected by additives is the degree of hardness and toughness. The following table summarizes the most common types of resins with their advantages and disadvantages.

Material type	Properties
Standard resin	<ul style="list-style-type: none"> ⊕ Smooth surface, lots of details ⊖ Fragile ⊖ Not suitable for mechanical parts
Clear resin	<ul style="list-style-type: none"> ⊕ Semi-transparent ⊖ Can be turned nearly fully transparent through post-processing
Casting resin	<ul style="list-style-type: none"> ⊕ Lots of details ⊕ Great for preparation of casting forms ⊕ Little to no remnants after burning the resin
Hard and resistant resins	<ul style="list-style-type: none"> ⊕ Similar to ABS or PP materials ⊕ Partially flexible ⊕ Suitable for mechanical parts ⊖ Low resistance to high temperatures
Heat-resistant resin	<ul style="list-style-type: none"> ⊕ Highly temperature-resistant ⊕ Used for injection forms ⊖ Expensive
Bio-compatible resins	<ul style="list-style-type: none"> ⊕ Non-toxic ⊕ Suitable for dental implants manufacturing ⊕ Abrasion-resistant ⊖ Expensive
Flexible resin	<ul style="list-style-type: none"> ⊕ Similar to rubber (70A hardness) ⊖ Lower resolution of printed parts

MULTI-COLOR 3D PRINTING

So far we've discussed only single-color 3D printing. So the obvious question is whether it's possible to print with multiple colors at the same time. Sure it is! There's even more than one option. There are advantages and disadvantages to currently available methods, so let's take a look at them.



What is the difference between multi-colored and fully-colored prints?

In our case, multi-colored print means an object printed with two to five colors. Full-color 3D printers can create any color, because they mix CMYKW colors.

The easiest way how to achieve multi-colored prints is by manually swapping the filament during the printing job. This is a good option for creating e.g. logos, banners or original business cards.

- ⊕ No need to modify your 3D printer.
- ⊕ No wasted material.
- ⊖ Needs to be done manually.
- ⊖ Only one color change per layer, not possible to have more colors in one layer.



If we take the previous method a couple of steps further, we'll end up with the Original Prusa Multi Material Upgrade 2S or Mosaic Palette. Essentially, these devices can swap filaments automatically, and even several times per single layer.

- ⊕ Enable filament changes within one layer.
- ⊕ Use the original (or slightly modified) single extruder - no need to calibrate multiple extruders.
- ⊖ Wasted material - the printer has to 'purge' material from the nozzle during filament changes.
- ⊖ Supports only up to 5 colors.
- ⊖ Not possible to mix colors to create new blends.



Full-color printing can be achieved by mixing filaments directly in the extruder. The principle is similar to regular ink printers, the only difference is that the ink is replaced with filaments. However, a 3D printer needs more than just CMYK filaments - white (W) filament is also required.

- ⊕ 4-5 filaments are enough for full-colored printing.
- ⊕ Saturated colors.
- ⊖ Lots of wasted material.
- ⊖ To achieve good colors, "calibrated" CMYKW filaments are required.

You can also achieve full-color printing with a combination of a 3D printer and a regular (ink) printer. The ink printer combines CMYK colors to achieve the required shade and the color is applied onto white filament, which absorbs the drops of color.

- ⊕ Any color is possible.
- ⊕ Only one filament is enough.
- ⊕ No wasted material.
- ⊖ Not possible to achieve fully saturated colors.



GLOSSARY

You can find the most commonly used terms and their explanation in the table below.

Term	Description and explanation
AMF/3MF file	File format used by slicer software to save the whole scene (models, placement and print settings)
FDM / FFF	3D printing technologies - additive manufacturing process. A filament string is loaded into an extruder, heated, melted and extruded. The printer has mechanical parts moving in three axes, allowing it to print any 3D object.
G-code	File that includes a list of commands for a 3D printer.
OBJ file	One of 3D object files supported by slicers, similar to STL.
PEI	A film on the surface of the printing sheet - good adhesion and easy maintenance.
RepRap	RepRap is the first open-source 3D printer project. It was founded in 2005 at the University of Bath by Adrian Bowyer. Now, the project is in the hands of the 3D printing community - hundreds of developers and tens of thousands of users.
Resin	Liquid material used for printing with SLA 3D printers. Also called photopolymer, because the solidifying process is initiated by UV light.
SLA / DLP	3D printing technologies that are based on curing liquid resin using UV light.
SLS	3D printing technology based on sintering of metal powders using a laser.
STL file	One of the supported file formats for slicers. It defines a set of points (vertices) in 3D space, which are connected to form edges and polygons. It's the most common type of files in the 3D printing industry.
bed, heatbed	Printing surface, usually with a heating unit to improve the adhesion.
bridging	The only case when printing in the air without supports is possible, however, it works only in a specific scenario. Bridging can create a straight line between two points with the same Z-axis height. This means the bridge has to be parallel to the printbed.

brim	Extra material printed around the base of the object to improve adhesion - especially useful for small objects.
extruder	The entire printing head. It usually consists of the hotend, feeding mechanism and a fan.
filament	Printing material used in FDM/FFF 3D printers.
firmware	Software running and controlling 3D printers.
heat break	A part of the hotend in the shape of a tube, which minimizes the transfer of heat between the heater block and the heatsink.
heater block	The lower part of the hotend made of heat-conducting materials. It contains a nozzle, heating module and a thermistor.
heater cartridge	Heating module, which heats the heater block along with the nozzle.
hotend	Part of the extruder that melts filament strings.
infill	Slicing settings, which determine how dense the inner structure of the printed object will be. 100% means a solid object. The usual number is between 10 and 20 %. This parameter has a major impact on the printing time and amount of material used.
layer	One layer of the object created through the slicing process. The recommended layer height shouldn't exceed $0.75 \times$ nozzle diameter. It has a major impact on the speed of printing. The lower layer height is used, the higher amount of details will be in the Z-axis.
mesh	A way of representation of a 3D model. A set of vertices, edges and polygons (facets) in three-dimensional cartesian coordinate system.
nozzle	A part of a 3D printer used to extrude melted plastic. It's diameter affects the quality and speed of the print. You can learn more at: blog.prusaprinters.org/nozzles .
overextrusion	A 3D printing error - an excessive amount of filament is pushed through the nozzle which results in an uneven surface of the printed object.
perimeter	Outside "wall" of a 3D printed object. Slicers have the option to change the number of perimeters. The thickness of a perimeter is defined by the nozzle diameter. When using a standard 0.4 mm nozzle, the perimeter thickness is 0.45 mm. The number of perimeters has a major impact on the printing time.
raft	A type of supports which is present under the whole first layer of the printed object.

retraction	An instruction that causes filament to be retracted back into the nozzle when the extruder is moving. By doing this, the melted string of filament is stopped from pouring out onto the model. Incorrect retractions can often manifest as stringing (see 'stringing').
skirt	A line around the printed object, usually several layers tall. It creates a microclima for the printed model and decreases the chance of bending, warping or cracking. Can be also used to calibrate the first layer height.
slicer	Software for converting (slicing) a 3D model into a machine code readable by 3D printers (G-Code). There's a number of them on the market, some are free, while other are paid - PrusaSlicer, Cura, Simplify3D etc. Slicer is not a modeling tool.
slicing	The process of converting a 3D model into a machine code readable by 3D printers. The process 'slices' the model into horizontal layers of defined height and creates the movement instructions for the extruder.
stringing	An unwanted effect manifested as thin strings of plastic ('hairs') on the surface of the object. Adjusting the retraction usually helps.
supports	Scaffolding-like structures used to print complex objects with either large overhangs or parts starting mid-air. The supports are printed with special settings, so it's rather easy to break them off from the printed object. However, FFF/FDM supports usually leave marks on the surface.
thermistor	Thermal sensor. Used for checking and adjusting the temperature of the hotend and heatbed.
under-extrusion	A 3D printing issue that occurs when an insufficient amount of filament is pushed through the nozzle, manifested as missing layers/ parts of the printed model. If the temperature settings are correct, the cause is usually a clogged nozzle.



FAQ

What is 3D printing?

3D printing is an automatized process, which enables manufacturing of real physical objects based on digital data (3D model).

How much does it cost to run a 3D printer?

Highest costs come from the material (filaments). The price for printing a single object depends mainly on its weight. 1 kg of filament usually costs around 20-30 USD. The energy consumption is similar to a 100W bulb. Servicing a regular 3D printer is quite cheap and it's usually less than a couple dozen USD a year.

What is 3D printing good for?

Rapid prototyping, customized model manufacturing, small-eries production – lower costs (and also lower quality) compared to injection molding.

Is FFF 3D printing considered eco-friendly?

As with many of manufacturing methods, even in 3D printing part of the processed material ends up as waste (supports, failed prints). However, a large majority of 3D printing materials can be recycled. The most used filament, PLA, is actually biodegradable because it's made of starch. Also, another thing to consider is the fact that thanks to 3D printing, we are now able to repair things that may have very well ended up in waste, which would be a bigger ecological burden. A handle for a fridge can be one of the examples.

Is it possible to print a house?

Yes, there's already a number of successful attempts using concrete or similar materials. It works the same way as 3D printing with plastics.

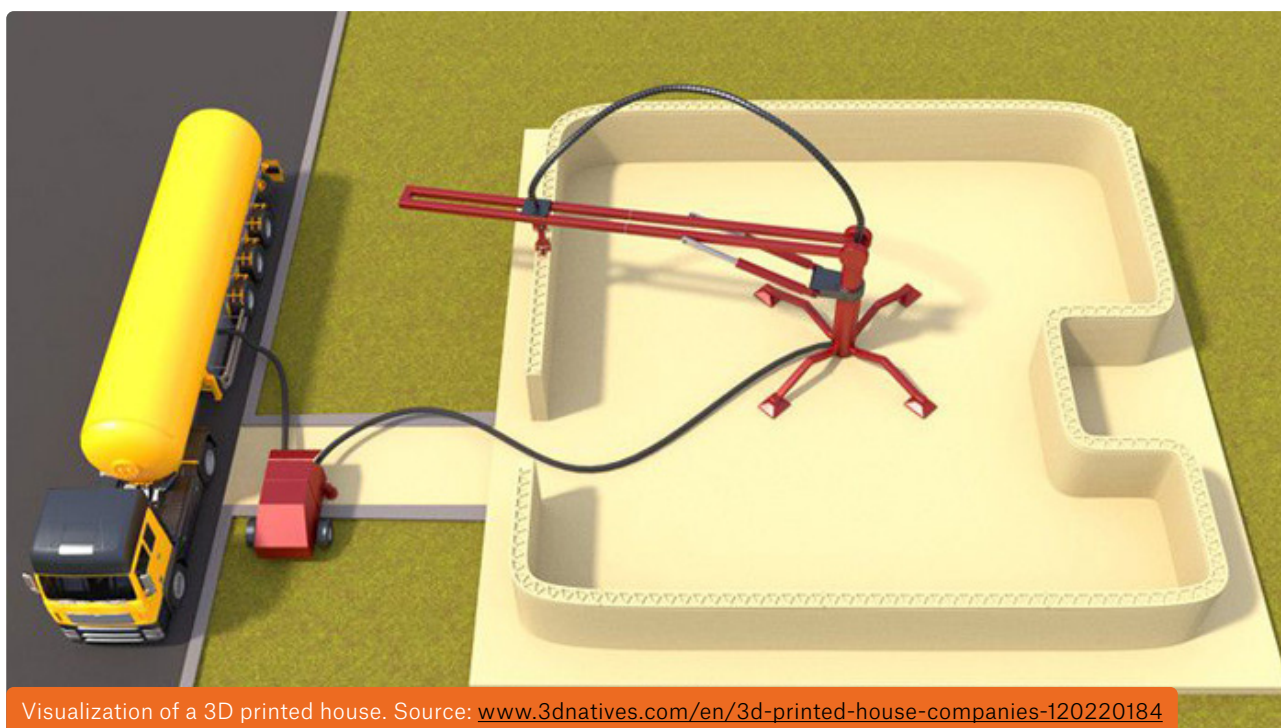

Visualization of a 3D printed house. Source: www.3dnatives.com/en/3d-printed-house-companies-120220184

Can 3D printers print human organs?

Not yet. However, scientists from all over the world are working hard to make this possible. There are news published about this topic almost every day. The problem (and the challenge) is the fact that human organs are incredibly complex and dependant on other organs. Scientists are focusing on printing tissues for less-complex organs, for now.

Can I print objects larger than the print surface?

Yes, it's possible to cut the model into pieces and glue them together after printing.

What is the difference between SLA and FFF technologies?

FFF (or FDM) 3D printing uses filament as the source material – a strand of plastic. The material is melted and extruded through the nozzle, which is a part of an extruder. SLA, on the other hand, is based on solidifying of liquid resins using UV light. Objects printed on FFF 3D printers have more visible layers compared to SLA. On the other hand, SLA printing has different disadvantages - such as the use of liquid resins, which are potentially harmful chemicals.

What kind of material is used for FFF 3D printing?

Various kinds of plastics, in some cases with additives. The most commonly used filaments are PLA, PETG and ABS.

How long does a print job take?

A simple question that is difficult to answer. It depends on many different factors: primarily, it's the size of the printed object, but also the density of the infill, number of perimeters, lower and upper shells, nozzle diameter, layer height, model complexity, number of supports and other factors.

Printing a figure 5 cm tall will take a couple of hours. However, with large and complex objects, you can easily get into dozens of hours of printing.

Most slicing apps can estimate the overall printing time.

What to do with empty filament spools?

Dispose of them in the plastic waste bins. Unfortunately, it's not possible (due to a number of reasons) to buy the empty spools back from the customers. If you don't feel like throwing them away, you can use them for a variety of projects - check out our article at: blog.prusaprinters.org/spools.

Is it possible to print food?

Surprisingly, yes! You will need a specially modified 3D printer (there's a number of them in the RepRap family) and you can print with chocolate, or even print pancake dough directly on a pan.

Can I print a cup or a plate and use it for drinking and eating?

Yes, but there's a couple of things to keep in mind! PETG and PLA are harmless plastics that can get in touch with food. However, it's not advised to use the printed objects for eating or drinking without post-processing them first. Tiny gaps in layers are perfect for accumulation of bacteria and it's nearly impossible to clean these parts well. Before you start using a printed cup, use food-safe epoxy to coat the sides.

Can I print erotic toys?

Yes, but rather just for display only. It's the same problem as with cutlery (cups, plates) - there are gaps between layers where bacteria tend to accumulate. It's possible to post-process the object and give it a coating to create a harmless surface.

Is it possible to 3D print a gun?

Theoretically, yes. If you take your time with post-processing, it can even look quite real. Would you put a real bullet in a plastic gun and pull the trigger, though? No? Neither would we! The plastic gun would most likely shatter in your hand and hurt you. Also, it would be impossible to take this gun through a metal detector, because the shell casing of the bullet would trip an alarm anyway. So maybe you're thinking: "How about using metal powder (SLS printing)?" Yes, that would be theoretically possible. However, this scenario is completely pointless due to the high price of manufacturing. If you, for whatever reason, want to produce a gun at home, a simple lathe is more than enough.

Basics of 3D Printing with Josef Prusa

Ondřej Stříteský

Published by:

Prusa Research a.s.
Partyzánská 188/7a
170 00 Praha
Česká republika

Co-authors:

Josef Průša, Martin Bach

Graphic design and typesetting:

Petr Memory Dragoun

Translated by:

Jan Olejník

First edition, Prague 2019